

# BCBC 2024 ILLUSTRATED GUIDE ON ACCESSIBILITY

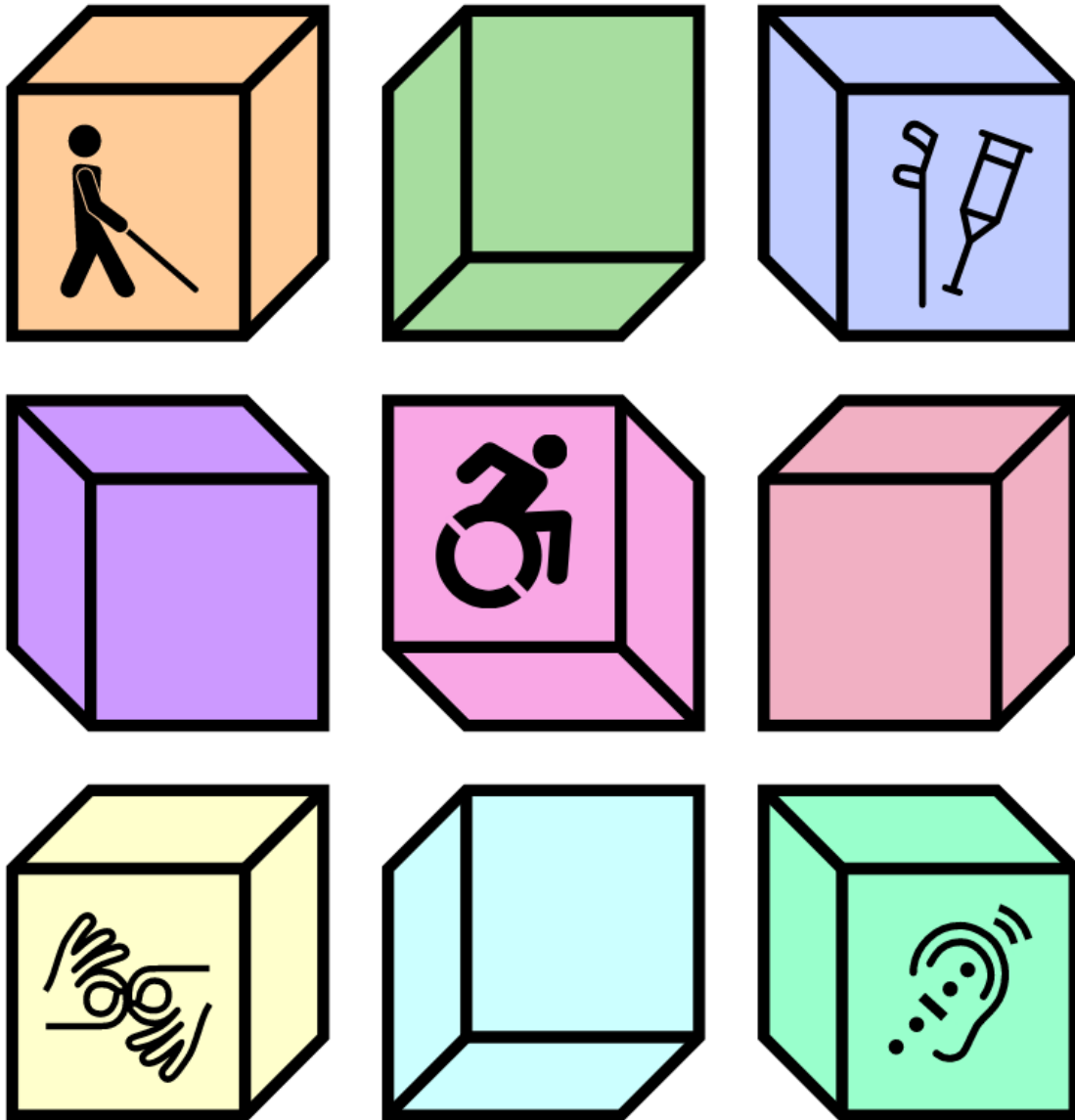

**An Illustrated Commentary on Accessibility Requirements  
In British Columbia Building Code 2024**

## TABLE OF CONTENTS

	<b>Page</b>
Context.....	3
Disclaimer .....	3
About GHIL Consultants Ltd. ....	3
Revisions.....	3
Revision History .....	4
(3.8.3.1.) Application of CSA B651-18.....	5
(3.8.1.1) Scope .....	6
(3.8.2.1) Application of Exceptions .....	6
<b>1.0 ACCESSIBLE ROUTES &amp; CIRCULATION .....</b>	<b>7</b>
(3.8.2.2) Application Requirements for Entrances .....	8
(3.8.2.3) Application Requirements for Areas Requiring Access.....	8
(3.8.2.4) Application Requirements for Escalators and Moving Walkways .....	10
(3.8.2.5) Application Requirements for Paths of Travel to Building Entrances & Loading Zones .....	10
(3.8.3.2) Accessible Paths of Travel .....	11
(3.3.1.8.) Corridor Projections.....	14
(3.8.3.3) Exterior Walks .....	15
(3.8.3.4) Passenger-Loading Zones .....	15
(3.8.3.5) Ramps .....	16
(3.8.2.7) Application Requirements for Power Door Operators.....	19
(3.8.3.6) Doorways and Doors.....	21
(3.8.3.7) Passenger Elevating Devices.....	27
(3.3.1.19.) Tactile Attention Indicators .....	28
<b>2.0 PLUMBING FACILITIES.....</b>	<b>29</b>
(3.8.2.8) Application Requirements for Plumbing Facilities .....	30
(3.8.3.10) Drinking Fountains .....	32
(3.8.3.11) Water Bottle Filling Stations .....	32
(3.8.3.12) Accessible Water-Closet Stalls .....	34
(3.8.3.13) Universal Washroom .....	37
(3.8.3.14) Water Closets .....	39
(3.8.3.15) Water Closet Stalls & Urinals for Persons with Limited Mobility .....	40
(3.8.3.16) Lavatories and Mirrors.....	43
(3.8.3.17) Showers.....	44
(3.8.3.18) Bathtubs .....	47
<b>3.0 OTHER ACCESSIBLE AREAS .....</b>	<b>49</b>
(3.8.2.11) Application Requirements for Counters .....	50
(3.8.3.20) Counters .....	50
(3.8.2.12) Application Requirements for Telephone .....	51
(3.8.3.21) Telephones.....	51
(3.8.2.3) Application Requirements for Wheelchair and Adaptable Spaces.....	52
(3.8.3.22) Spaces in Seating Areas .....	53
(3.8.2.13) Application Requirements for Sleeping Rooms and Bed Spaces .....	54
(3.8.3.23) Sleeping Rooms and Bed Spaces .....	54
(3.2.4.19) Visible Signals .....	54

<b>4.0</b>	<b>ACCESSIBLE CONTROLS, SIGNS &amp; DEVICES</b>	<b>55</b>
(3.8.2.6)	Application Requirements for Controls and Outlets	56
(3.8.3.8)	Controls and Outlets	56
(3.8.2.10)	Application Requirements for Signs and Indicators	57
(3.8.3.9)	Accessible Signs	58
(3.4.5.2.)	Exit Signs with Tactile Information	60
(3.4.6.19.)	Floor Numbering at Exit Stairs	60
(3.4.6.19.)	Identification of Stair Shafts	60
(3.4.6.18.)	Crossover Signs	60
(3.4.6.16.)	Maglock Signs	61
(3.5.4.2.)	Floor Numbering at Elevators	61
(3.2.7.1.)	Illumination on Signs	61
(3.8.2.9)	Application Requirements for Assistive Listening Systems	62
(3.8.3.19)	Assistive Listening Systems	62
(3.2.7.1)	Minimum Lighting Requirements	63
<b>5.0</b>	<b>ADAPTABLE DWELLING UNITS</b>	<b>64</b>
(3.8.5.1)	Application	65
(3.8.5.2)	Construction Requirements	65
(3.8.5.3)	Building Access Requirements	66
(3.8.5.4)	Doors	66
(3.8.5.5)	Hallways and Corridors	68
(3.8.5.6)	Bedrooms	69
(3.8.5.7)	Bathrooms	70
(3.8.5.8)	Kitchens	72
(3.8.5.9)	Controls, Switches and Outlets	73
(3.2.4.19)	Special Outlet for Future Strobe	73
<b>6.0</b>	<b>ADAPTABLE UNIT EXAMPLE PLANS</b>	<b>74</b>

## Context

This illustrated guide based on the 2024 British Columbia Building Code (BCBC) accessibility and adaptability requirements was developed on the idea that a photo says a million words and inspired by the Building Accessibility Handbook 2020 and ones before it.

By using visuals, this guide aims to complement the wording of the Building Code by providing clarity of what the Code requirements entail based on our experience and interpretation. Visual representations have the power to simplify complex concepts, making them more digestible and easier to comprehend for a wider audience.

The intention isn't to replace the textual content of the Code but rather to enhance it by offering visual aids that bring its requirements to life and to significantly improve understanding, compliance, and adherence to the regulations set forth in the Building Code.

Ultimately, the goal of this illustrated guide is to empower individuals involved in construction and design projects to better understand and apply the regulations outlined in the Building Code. It aims to serve as a practical, user-friendly guide that complements the official text of the Code.

## Disclaimer

GHL has prepared this guide to assist the design community based on our review and understanding of the 2024 BC Building Code. If distributed, this guide should be distributed and reviewed in its entirety.

The provisions from the 2024 BC Building Code outlined in this guide are for reference purposes only. Users are advised to consult the official 2024 British Columbia Building Code when applying building regulations for project specific application.

We take no responsibility for accuracy or completeness unless we are specifically retained to participate in a project and related to the specific project scope. We are happy to provide proposals for assistance on your project, please contact [tech@ghl.ca](mailto:tech@ghl.ca).

## About GHL Consultants Ltd.

GHL is a consulting firm specialized in the practice of fire engineering and Building Code consulting. Our services focus on fire safety regulations in Division B, Part 3 and Part 9 of the BC and related Building Codes and the Vancouver Building Bylaws along with related Certified Professional Services.

Since our establishment, we have successfully provided consulting services to address a wide range of Building Code requirements and fire engineering problems in projects ranging from small buildings to large complex, mixed-use buildings. These projects, using a variety of construction materials and methods, often require alternate solutions to construction details not specifically addressed by Codes or Standards. For further information visit our website at [www.ghl.ca](http://www.ghl.ca).

Suite 800 – 700 West Pender Street  
Vancouver BC V6C 1G8  
Phone: (604) 689-4449  
Email: [tech@ghl.ca](mailto:tech@ghl.ca)  
Web: [www.ghl.ca](http://www.ghl.ca)

## Revisions

This guide is an ever-evolving resource, designed to remain dynamic and responsive to ongoing changes in the Code. As revisions are made to the Code, this document will adapt accordingly, ensuring it reflects the latest requirement along with interpretations and appeals. Additionally, our commitment extends to continuously augmenting this guide with supplementary notes, interpretations, and diagrams.

Not sure if you have the latest version, check on our website library at [www.ghl.ca/library/](http://www.ghl.ca/library/).





### (3.8.3.1.) Application of CSA B651-18

- 1) **Accessible Design:**  
Buildings or parts thereof and facilities that are required to be accessible shall be designed in accordance with
- this Subsection, or
  - for each accessible application listed independent of other accessible applications, the applicable provisions of CSA B651, "Accessible design for the built environment," listed in Table 3.8.3.1.,

(See Note A-3.8.3.1.(1).)

**Note A-3.8.3.1.(1)**

Accessible Design Standards. Code users who opt to apply the provisions of CSA B651, "Accessible design for the built environment," listed in Table 3.8.3.1. must do so without exception: they cannot randomly select and apply a mix of provisions from this Code and that standard.

- 2) **Compliance Path:**  
The design of each accessible application listed in Table 3.8.3.1. shall comply entirely with Clause (1)(a) or Clause (1)(b)



**Table 3.8.3.1.  
Accessible Design Provisions  
Forming Part of Sentence 3.8.3.1.(1) and (2)**

Accessible Application (BCBC 2024)	Applicable CSA B651 2018 Provisions
Interior accessible routes (3.8.3.2.)	4.3 and 5.1
Exterior accessible routes (3.8.3.3.)	8.2.1 to 8.2.5 and 8.2.7
Passenger pickup areas (3.8.3.4.)	9.3
Ramps (3.8.3.5.)	5.3 and 5.5
Doors and doorways (3.8.3.6.)	5.2
Passenger-elevating devices (3.8.3.7.)	5.6.2
Operating controls (3.8.3.8.)	4.2
Signage (3.8.3.9.)	4.5 and 9.4
Drinking fountains (3.8.3.10.)	6.1
Washroom facilities (3.8.3.12. to 3.8.3.16.)	6.2 and 6.3
Bathing facilities (3.8.3.17. and 3.8.3.18.)	6.5
Communication (3.8.3.19. and 3.8.3.21.)	6.6
Counters (3.8.3.20. and 3.8.3.21.)	6.7.1
Spaces in seating areas (3.8.3.22.)	6.7.3

### (3.8.1.1) Scope

- 1) **Overview:**  
This Section is concerned with the design and construction of buildings and occupancies to make them accessible.
- 2) **Requirements and Implementation:**  
Buildings and facilities required to be accessible in accordance with Subsection 3.8.2. shall be designed in accordance with Subsection 3.8.3.
- 3) **Existing Building Alterations & Additions:**  
Alterations and additions to existing buildings shall conform to Subsection 3.8.4.
- 4) **Adaptable Dwelling Units:**  
Dwelling units required to be adaptable dwelling units shall be designed in accordance with Subsection 3.8.5.  
< *Reserved for Adoption in 2025* >

### (3.8.2.1) Application of Exceptions

- 1) **Exceptions:**  
Except as required by Sentence (2), the requirements of this Section apply to all buildings except
  - a) detached houses, semi-detached houses, houses with a secondary suite, duplexes, triplexes, townhouses, row houses and boarding houses (see Note A-1.4.1.2.(1) of Division A, Secondary Suite),
  - b) buildings of Group F, Division 1 major occupancy, and
  - c) buildings that are not intended to be occupied on a daily or full-time basis, including automatic telephone exchanges, pumphouses and substations.
- 2) **Houses Requiring Backing for Future Grab Bars:**  
Buildings described in Clause (1)(a) shall comply with Sentence 3.8.5.1.(2).

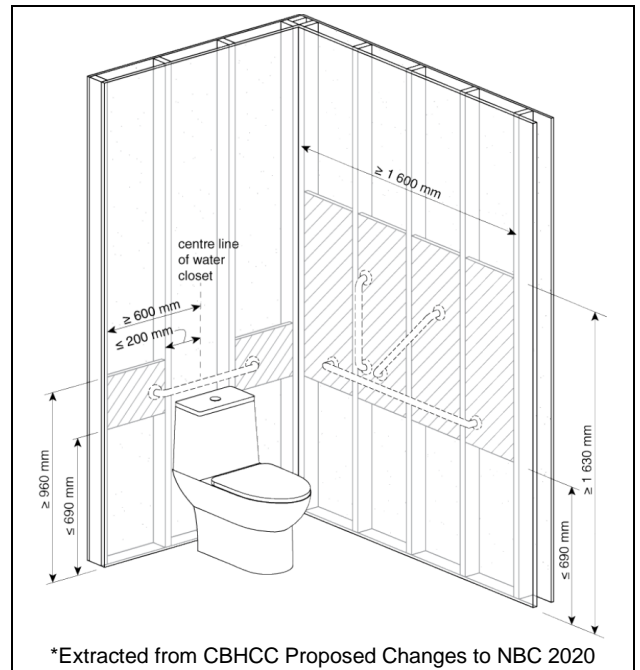

3.8.2.1.(2) Grab Bar Reinforcement Example

# 1 ACCESSIBLE ROUTES & CIRCULATION





### (3.8.2.2) Application Requirements for Entrances

- 1) **Required Accessible Entrances:**  
Except for service entrances and entrances to suites described in Clause 3.8.2.3.(2)(l), all pedestrian entrances to an accessible storey of a building referred to in Sentence 3.8.2.1.(1) shall be accessible and shall connect to an accessible exterior path of travel complying with Sentence 3.8.2.5.(1).
- 2) **Design of Accessible Entrances:**  
An accessible entrance required by Sentence (1) shall be designed in accordance with Subsection 3.8.3.
- 3) **Entrances with Multiple Doors:**  
At an accessible entrance that includes more than one doorway, only one of the doorways is required to be designed in accordance with Subsection 3.8.3.
- 4) **Connection of Accessible Storeys:**  
If a walkway or pedestrian bridge connects two accessible storeys in different buildings, the path of travel from one storey to the other storey by means of the walkway or bridge shall be accessible.

### (3.8.2.3) Application Requirements for Areas Requiring Access

- 1) **Accessible access:**  
Except as permitted by Sentence (2), an accessible path of travel from the entrances required by Sentence 3.8.2.2.(1) to be accessible shall be provided throughout the entrance storey and within all other normally occupied areas of buildings. (See Article 3.3.1.7. for additional requirements regarding floor areas which an accessible path of travel is required.)
- 2) **Not Required Accessible Access:**  
Access is not required
  - a) to service rooms,
  - b) to elevator machine rooms,
  - c) to janitors' rooms,
  - d) to service spaces,
  - e) to crawl spaces,
  - f) to attic or roof spaces,

- g) to the floor level above or below the entrance level in suites with more than one level, provided the floor level above or below (see Note A-3.8.2.3.(2)(g))
  - i) is not served by a ramp, a passenger elevator, a platform-equipped passenger-elevating device, an escalator or an inclined moving walk,
  - ii) is less than 600 m<sup>2</sup> in floor area,
  - iii) contains only facilities that are also contained on the entrance level, and
  - iv) does not contain an assembly occupancy more than 100 m<sup>2</sup> in floor area,

#### Note A-3.8.2.3.(2)(g)

Access to Facilities on a Floor Level other than the Entrance Level. Subclauses 3.8.2.3.(2)(g)(ii) to (iv) are intended to exempt certain storeys other than the entrance level - including basements and mezzanines that are less than 600m<sup>2</sup> in floor area or 100m<sup>2</sup> or less in floor area in assembly occupancies, that are self-contained and that contain the same facilities as the entrance level from the requirement to have an accessible path of travel.

Examples of buildings and spaces to which this exemption may apply are small office buildings with additional workspaces on the second storey and small restaurants with a second storey that contains only additional seating. However, if a restaurant's only washrooms are in the basement, they must have an accessible path of travel as they are an integral part of the principal function of the first storey. Similarly, staff lunchrooms and washrooms are also integral to the principal function of a restaurant; as such, if they are located in a floor area such as a second storey, basement or mezzanine that contains the only facilities, they must have an accessible path of travel for potential employees with disabilities.

Mezzanines that are not considered as stories for the purpose of determining building height are considered as stories for the purpose of applying Clause 3.8.2.3.(2)(g).

- h) within a parking level with no accessible parking spaces,
- i) within high-hazard industrial occupancies
- j) within floor levels of a suite of residential occupancy that are not at the same level as the entry level to the suite,
- k) within floor levels of a suite of residential occupancy that are not at the same level as the entry level to the suite, *< Reserved for Adoption in 2025 >*
- l) within a suite of residential occupancy that has not been designated by this Code or an authority having jurisdiction to be accessible or designed and constructed as an adaptable dwelling unit, or *< Reserved for Adoption in 2025 >*

- m) in a building of residential occupancy that is not more than two storeys that contains multiple dwelling units and common interior space served by a common building entrance, on a floor level that
- is not served by a ramp, passenger elevator, a platform-equipped passenger-elevating device, an escalator or an inclined moving walk,
  - is less than 600m<sup>2</sup> in floor area,
  - is not a building entrance level, and
  - does not contain common facilities that are not also provided on an accessible level.

**3) Wheelchair Spaces in Assembly Occupancies:**

In an assembly occupancy, the number of spaces designated for wheelchair use within rooms or areas with fixed seats shall conform to Table 3.8.2.3.

**4) Wheelchair Spaces in Waiting Room or Area with Fixed Seats:**

The number of spaces designated for wheelchair use within waiting rooms or areas with fixed seats shall conform to Table 3.8.2.3. (See Note A-3.8.2.3.(4).)

**Note A-3.8.2.3.(4)**

Waiting Areas with Fixed Seats. Many types of buildings have waiting areas, such as airports, hospitals, and government office buildings. Waiting areas should have a sufficient number of spaces designated for persons using wheelchairs so they can use the waiting area without blocking any means of egress.

The number of people using wheelchairs is typically much higher in treatment occupancies than in other types of occupancies. Designers should consider adding more designated wheelchair spaces in waiting areas than the numbers indicated in Table 3.8.2.3. in occupancies where a higher number of persons using wheelchairs is expected due to the types of services provided.

**Table 3.8.2.3.  
Designated Wheelchair Spaces Forming  
Part of Sentences 3.8.2.3.(3) and (4)**

# of Fixed Seats in Seating Area	# of Wheelchair Spaces Required for Wheelchairs
2 – 99	2
100 – 499	3 plus 1 for each additional increment of 70 seats in excess of 100
500 – 1999	9 plus 1 for each additional increment of 80 seats in excess of 500
2000 – 7999	28 plus 1 for each additional increment of 95 seats in excess of 2000
Over 7999	91 plus 1 for each additional increment of 100 seats in excess of 8000

**5) Adaptable Seating in Assembly Occupancies:**

Except as provided in Sentence (6), in an assembly occupancy with more than 25 fixed seats, each row of seats served by two aisles shall have one adaptable seat conforming to Subsection 3.8.3. located adjacent to one of the aisles.

**6) Adaptable Seating Location:**

At least 5% of the adaptable seats required by Sentence (5) but no more than 20 adaptable seats shall adjoin an accessible path of travel.

*< Refer to Section 3 of this guide on Sentences (3) to (6) for more details regarding wheelchair spaces and adaptable seating in assembly occupancies with fixed seating >*

### (3.8.2.4) Application Requirements for Escalators and Moving Walkways

- 1) **Required Accessible Entrances:**  
In a building in which a ramp, escalator or inclined moving walk provides access to any floor level, an interior accessible path of travel shall also be provided to that floor level.

#### Note A-3.8.2.4.(1)

Accessible Path of Travel to Storeys Served by Escalators and Moving Walks. In some buildings, escalators and inclined moving walks are installed to provide transportation from one floor level to another floor level so as to increase the capacity to move large numbers of persons. Some buildings located on a sloping site are accessible from street level on more than one storey and an escalator or inclined moving walk is provided for internal movement from floor to floor. In both these situations, people must be provided with an equally convenient means of moving between the same floor levels within the building. This may be accomplished by providing elevators, platform-equipped passenger-elevating devices, or ramps, for example.

- 2) **Direction to Accessible Route:**  
The route from the ramp, escalator or inclined moving walk to the accessible path of travel that leads from floor to floor as required by Sentence (1) shall be clearly indicated by appropriate signs.

### (3.8.2.5) Application Requirements for Paths of Travel to Building Entrances & Loading Zones

- 1) **Exterior Accessible Path Location:**  
A direct exterior accessible path of travel that complies with Subsection 3.8.3. shall be provided between an accessible entrance referred to in Article 3.8.2.2. and
- a designated accessible parking area, where provided,
  - an exterior passenger-loading zone, where provided,
  - common ancillary buildings on the lot, and
  - a public thoroughfare
- 2) **Accessible Paths at Storage Garage Levels:**  
In storage garages, an accessible path of travel that complies with Subsection 3.8.3. shall be provided between each parking level with parking spaces designated for persons with disabilities and all other parts of the building required to be provided with access in accordance with Subsection 3.8.2. that are served by that storage garage. (See Note A-3.8.2.5.(1) and (2).)

#### Note A-3.8.2.5.(1) and (2)

Exterior Accessible Paths of Travel. The intent of Sentences 3.8.2.5.(1) and (2) is to ensure that exterior accessible paths of travel are readily available, direct and accessible so that persons of all abilities can move to and from a building with minimal effort.

- 3) **Accessible Paths at Passenger Loading Zones:**  
Exterior passenger-loading zones shall comply with Subsection 3.8.3.

#### Note A-3.8.2.5.

Parking Areas. In localities where local regulations or bylaws do not govern the provision of or dimensions of accessible parking spaces, the CSA B651, "Accessible design for the built environment," standard as well as the following provides guidance to determine appropriate provisions. If parking spaces are provided, parking spaces for use by persons with physical disabilities should be provided in proportion considerate of anticipated use. Where parking spaces are provided, parking spaces for use by persons with physical disabilities should be provided for each accessible viewing position and for each accessible sleeping room or bed space. Parking spaces for use by persons with physical disabilities should.

(1) be not less than 2 600 mm wide, provided on one side with an access aisle not less than 2 000 mm wide, provided a perpendicular and adjacent rear access aisle not less than 2 000 mm wide, and have a clear height contiguous with the routes of the vehicular approach and exit of not less than 2 750 mm,

(2) have a firm, slip-resistant and level surface,

(3) be located close to an entrance required to conform to Article 3.8.2.2.,

(4) be clearly marked as being for the use of persons with physical disabilities, and

(5) be identified by a sign located not less than 1 500 mm above ground level, with the International Symbol of Access.



Asphalt, concrete and firm, compacted gravel are acceptable parking surfaces. Curb ramps should be not less than 920 mm wide. Parallel parking spaces should be not less than 7 000 mm long. If more than one parking space is provided for persons with physical disabilities, a single access aisle can serve two adjacent parking spaces. Parking to accommodate vans and other vehicles equipped with platform lifts or side ramps should be provided greater dedicated space. The design of the path of travel should accommodate loading to and from lifts and ramps including the necessary vehicle clearances

### (3.8.3.2) Accessible Paths of Travel

#### 1) Clear Width:

Except as required elsewhere in this Part or as permitted by Sentence (2) and Article 3.8.3.6. pertaining to doorways, the clear width of an accessible path of travel shall be not less than 1 000 mm.

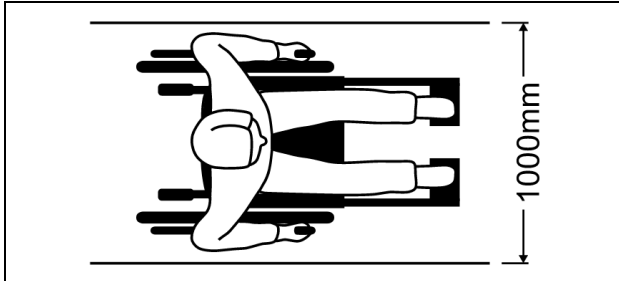

3.8.3.2.(1) Clear Width

#### 2) Reduction in Clear Width:

The clear width of an accessible path of travel is permitted to be reduced to not less than 850 mm for a length of not more than 600 mm, provided the clear floor space at either end of the reduced-clear width section is level within a rectangular area

- with a dimension parallel to each end of the reduced-clear width section is not less than 1 000 mm, and
- with a dimension perpendicular to each end of the reduced-clear width section is not less than 1 500 mm.

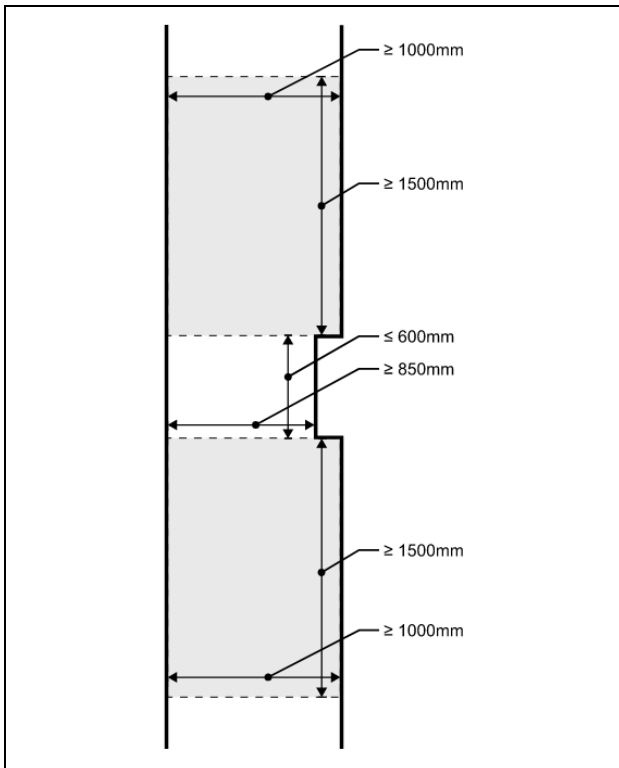

3.8.3.2.(2) Reduced Clear Width

#### 3) Accessible Walking Surfaces:

Accessible interior and exterior paths to

- have no opening that will permit the passage of a sphere more than 13 mm in diameter,
- have any elongated openings oriented approximately perpendicular to the direction of travel,
- be stable, firm and slip-resistant,
- have a cross slope no steeper than 1 in 50,
- be beveled at a maximum slope of 1 in 2 at changes in level between 6 mm and 13 mm,
- be provided with sloped floors or ramps at changes in level more than 13 mm, and
- be designed as a ramp complying with this Section where the path of travel has a slope steeper than 1 in 20.

(See Note A-3.8.3.2.(3).)

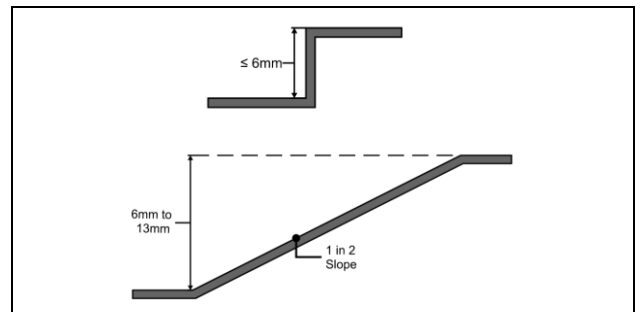

3.8.3.2.(3) Walking Surface Level Change

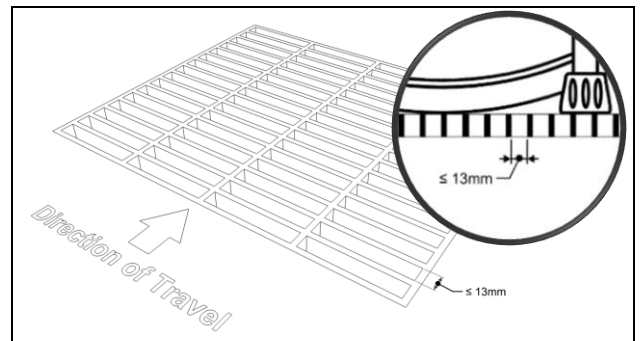

3.8.3.2.(3) Opening in Walking Surface

#### Note A-3.8.3.2.(3)

Surfaces in an Accessible Path of Travel. Floor finishes, including walk-off mats and carpet, should be selected, installed and securely fixed to provide a firm and stable surface so that people, including those who use mobility aids, can easily travel over them without tripping or expending undue energy. Other than very high-density, short-pile carpeting, most carpeting does not meet these criteria.

Furthermore, where the path of travel is exposed to intense light conditions, such as daylight or directional lighting, a low-glare or matte floor surface should be selected, as glare from floor surfaces can influence all users' perception, particularly those with vision loss. For the same reasons, heavily patterned flooring should also be avoided.

- 4) **Accessible Path at Changes in Elevations:**  
An accessible path of travel is permitted to include ramps, passenger elevators or other platform-equipped passenger-elevating devices to overcome a difference in level.
- 5) **Bump-Outs:**  
The width of an accessible path of travel that is more than 24 m long shall be increased to not less than 1 700 mm for a length of 1 700 mm at intervals not exceeding 24 m.

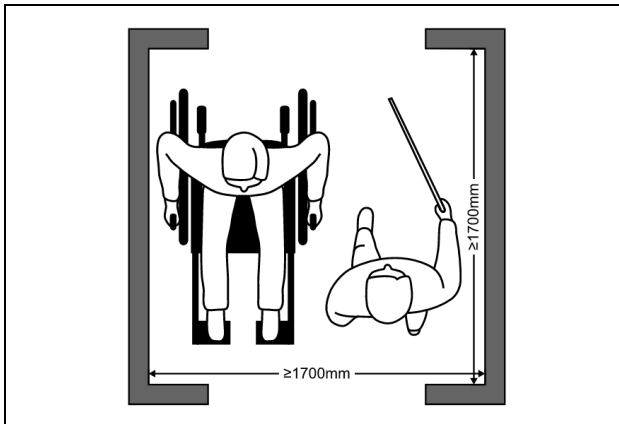

3.8.3.2.(5) Bump-Out Size

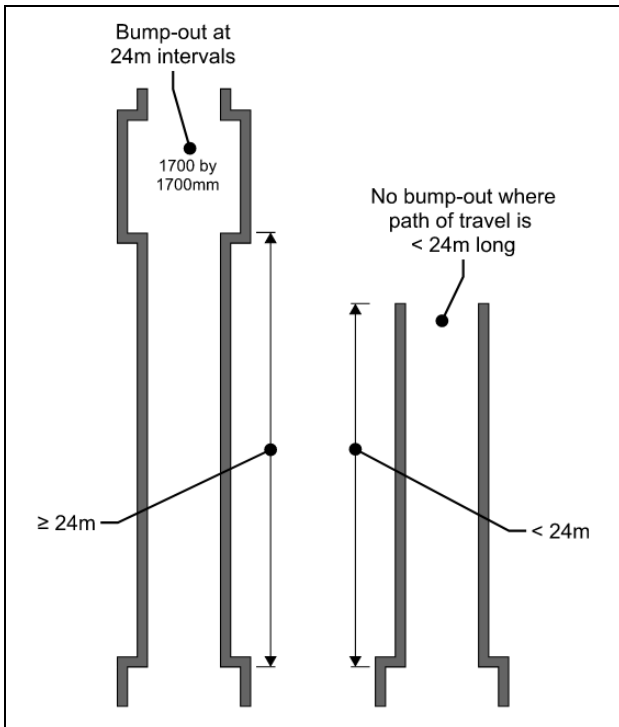

3.8.3.2.(5) Bump Out Locations

- 6) **Turn Around Space:**  
Where a section of an accessible path of travel is less than 1 500 mm wide for a distance of more than 12 m, it shall end in a clear floor space that is
  - a) not less than 1700 mm in diameter,
  - b) not less than 1700 mm by 1500 mm, or
  - c) T-shaped with overall dimensions measuring 1 700 mm wide by 1 500 mm long, where the two arms of the "T" are not less than 1 000 mm wide and extend not less than 300 mm from each side of the base of the "T" and the base is not less than 1 000 mm wide and extends not less than 500 mm from each arm.

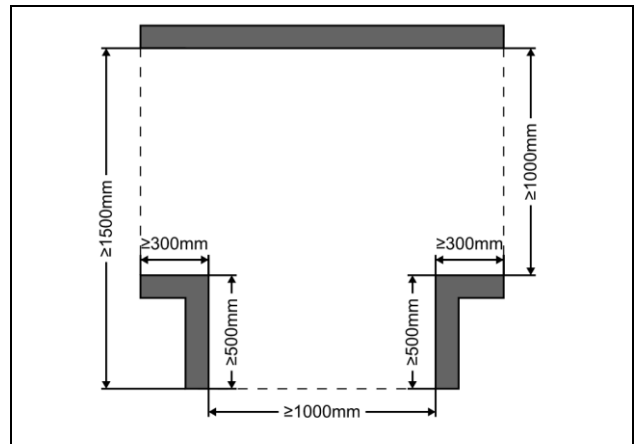

3.8.3.2.(6)(c) Turn Around Space

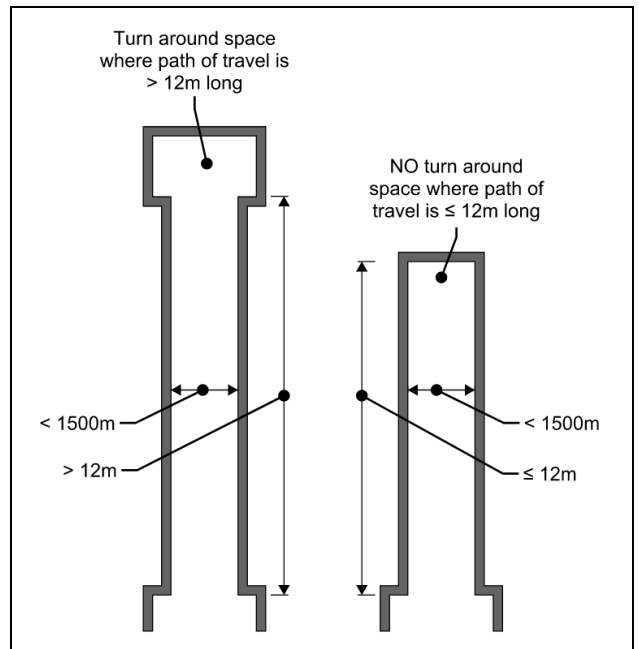

3.8.3.2.(6) Turn Around Space Locations

- 7) **Lighting Levels:**  
An accessible path of travel shall be equipped to provide illumination in accordance with Sentences 3.2.7.1.(1) and (2). (See also Sentences 3.2.7.1.(3) and Article 9.34.2.7.)

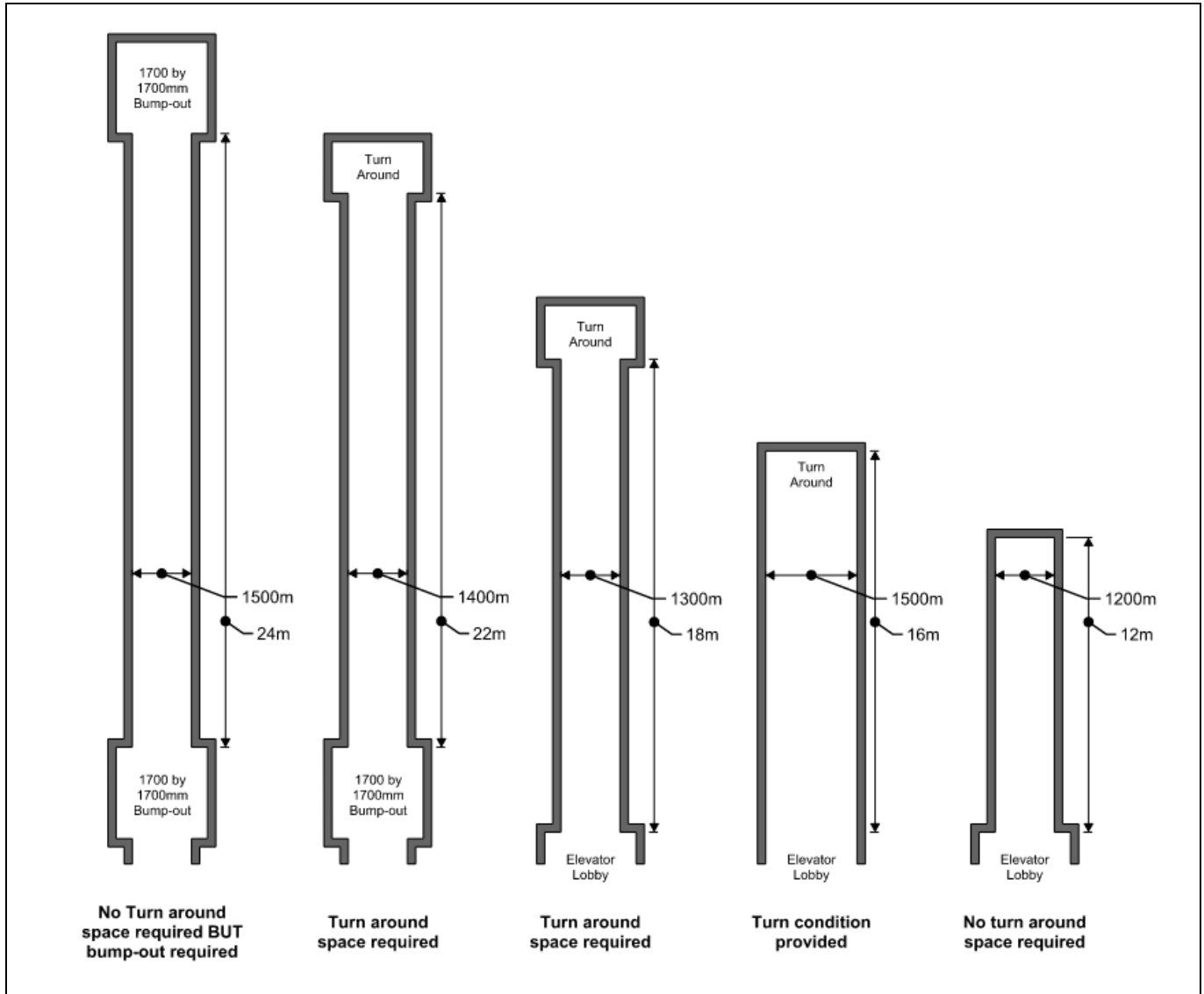

3.8.3.2.(5) &amp; (6) Corridor Example Conditions

**(3.3.1.8.) Corridor Projections**

- 1) **General Headroom Clearance:**  
Except within the floor area of a storage garage, the minimum headroom clearance in every access to exit shall conform to the requirements of Article 3.4.3.4. for exits. (See also Sentence 3.3.5.4.(5).)
- 2) **Projections into Path of Travel:**  
Except as permitted by Sentence (3) and except for paths of travel in service rooms and dwelling units, protruding building elements located within 1 980 mm of the floor shall not project more than 100 mm horizontally into paths of travel in a manner that would create a hazard. (See Note A-3.3.1.8.(2) and (3).)
- 3) **Projection Identification:**  
The horizontal projection of a protruding building element referred to in Sentence (2) is permitted to be more than 100 mm, provided the clearance between the protruding element and the floor is less than 680 mm. (See Note A-3.3.1.8.(2) and (3).)

**Note A-3.3.1.8.(2) and (3)**

Protruding Building Elements in Paths of Travel. The term "protruding building elements" refers to elements regulated by this Code that are permanently affixed to the building and protrude into the path of travel.

The sweep of a cane normally detects protruding building elements that are within 680 mm of the floor. Any protruding element above this height would not normally be detected and can, therefore, create a hazard if it projects more than 100 mm into the path of travel.

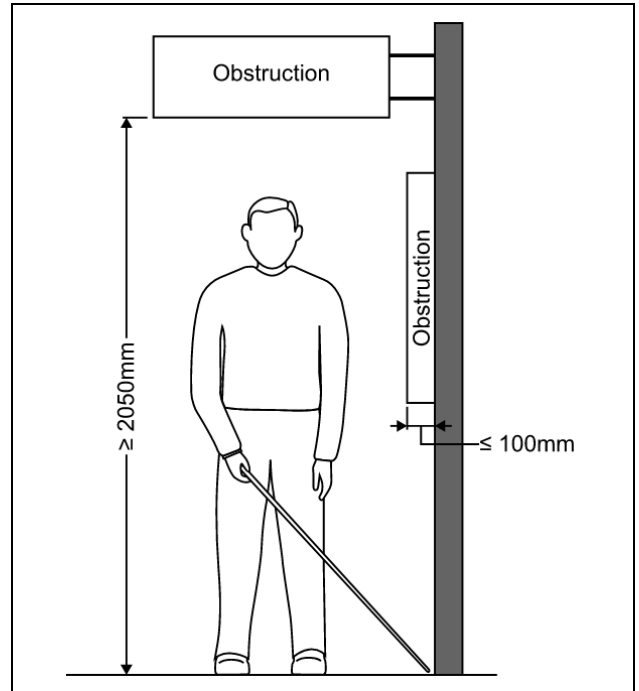
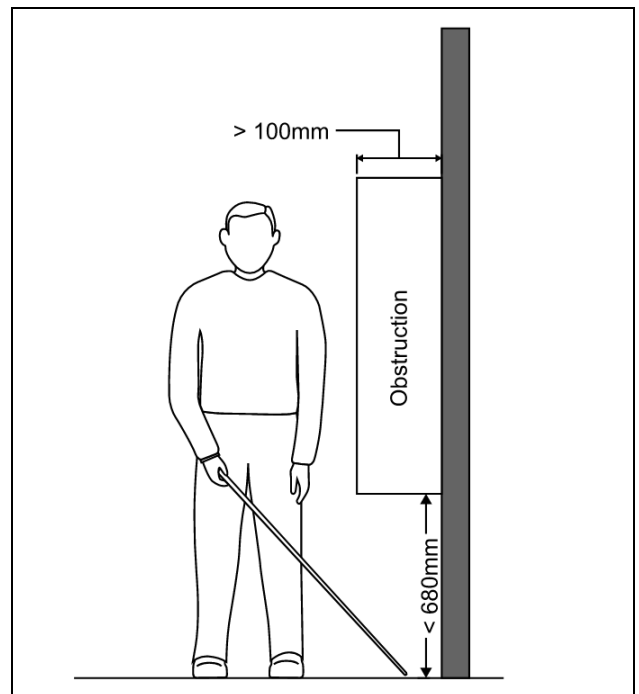
**3.3.1.8.(2) Cane Detects Wall****3.3.1.8.(3) Cane Detectable Obstruction**

**(3.8.3.3) Exterior Walks****1) Exterior Walk Design:**

Exterior walks that form part of an accessible path of travel shall

- have a slip-resistant, continuous and even surface,
- be not less than 1 600 mm wide,
- have a level area conforming to Clause 3.8.3.5.(1)(c) adjacent to an entrance doorway, and
- be designed in accordance with Clause 8.2.1 of CSA B651, "Accessible design for the built environment."

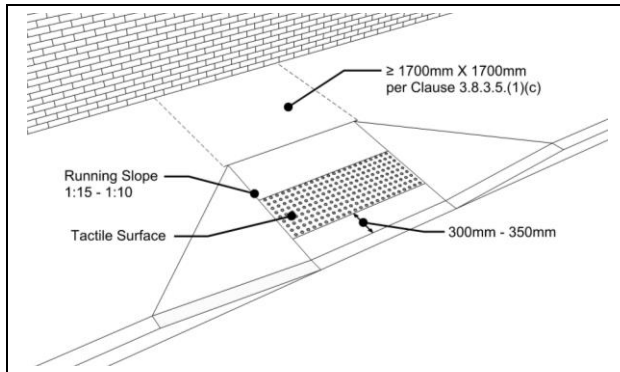
**3.8.3.3.(1) Curb Ramp Design****(3.8.3.4) Passenger-Loading Zones****1) Passenger-Loading Zone Design:**

If a passenger-loading zone is provided, it shall have

- an access aisle not less than 1 500 mm wide and 6 000 mm long adjacent and parallel to the vehicle pull-up space,
- a curb ramp, designed in accordance with Clause 8.3.3. of CSA B651, "Accessible design for the built environment," where there are curbs between the access aisle and the vehicle pull-up space, and
- a clear height of not less than 2 750 mm at the pull-up space and along the vehicle access and egress routes.

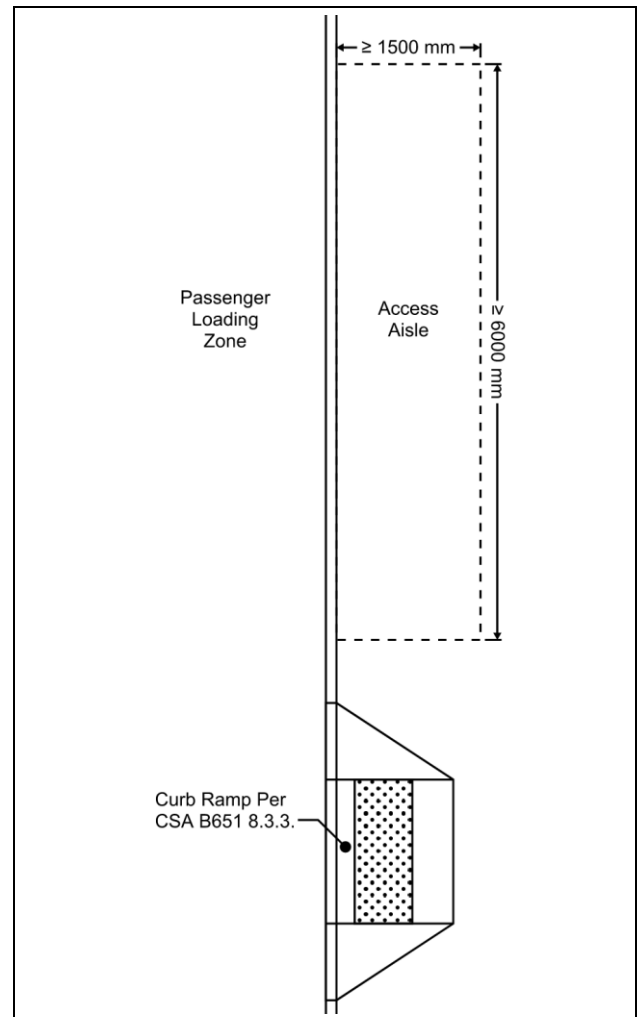
**3.8.3.4.(1) Passenger-Loading Zone Design**



### (3.8.3.5) Ramps

#### 1) Ramp Design:

Except when designed as a curb ramp in accordance with Clause 3.8.3.4.(1)(b), a ramp located in an accessible path of travel shall

- have a clear width not less than 1 000 mm (see Note A-3.4.3.4.),
- have a uniform slope along its length not more than 1 in 12 (see Note A-3.8.3.5.(1)(b)),

#### Note A-3.8.3.5.(1)(b)

Ramp Slopes. Ramps with a slope of more than 1 in 16 can be very difficult for persons with certain physical disabilities with upper body mobility to manage. Even though they pose less of a problem for persons using motorized wheelchairs, these ramps can be unsafe to descend, especially in cold climates. Although Article 3.8.3.5. permits slopes on ramps as great as 1 in 12 for distances of up to 9 m, slopes of 1 in 20 are safer and less strenuous. When limited space is available, as may be the case during renovations, ramps with a slope of up to 1 in 12 should be restricted to lengths not exceeding 3 m whenever possible. A strip contrasting in colour and texture should be used at the top and bottom of ramps to warn persons with low or no vision. The phrase “uniform slope along its length” is intended to mean that the slope remains constant along the length of individual ramp segments.

- have a level area not less than 1 700 mm by 1 700 mm at the top and bottom and at intermediate levels of a ramp leading to a door, so that on the latch side the level area extends not less that
  - 600 mm beyond the edge of the door opening where the door opens towards the ramp, or
  - 300 mm beyond the edge of the door opening where the door opens away from the ramp
- have a level area not less than 1 350 mm long and at least the same width as the ramp
  - at intervals not more than 9 m along its length, and
  - where there is an abrupt change in the direction of the ramp, and

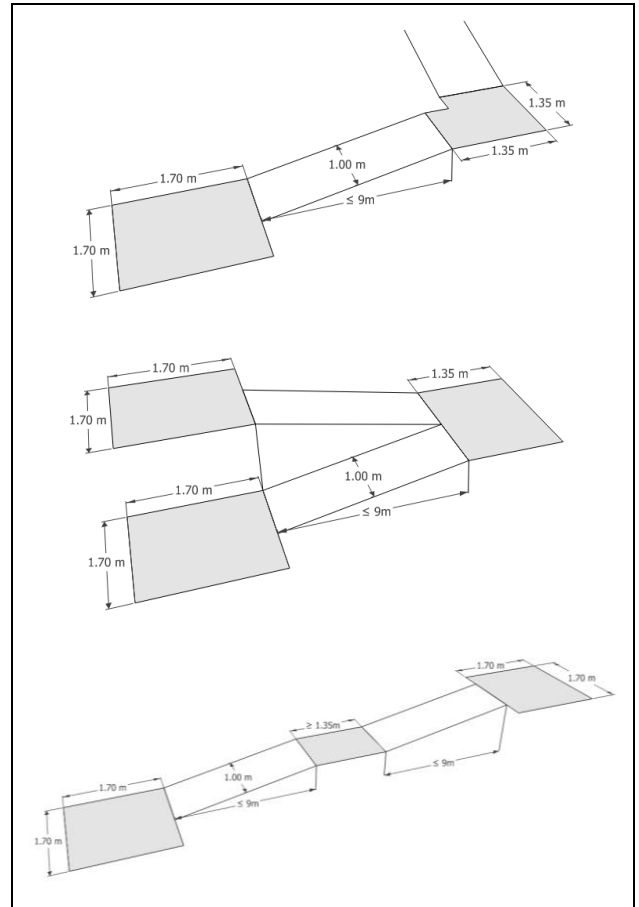

3.8.3.5.(1) Ramp Landing Required Level Areas

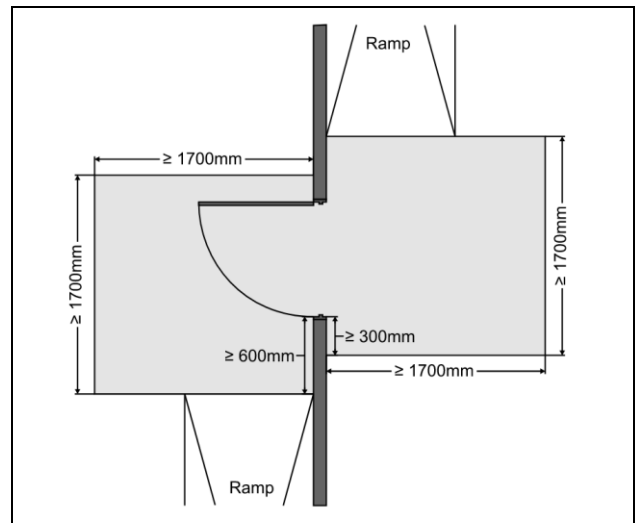

3.8.3.5.(1) Ramp Landing at Door

- e) except as provided in Sentences (2) and (3), be equipped with handrails conforming to Article 3.4.6.5., except that they shall be not less than 865 mm and not more than 965 mm high, and
- f) be equipped with guards conforming to Article 3.4.6.6.
- 2) **Additional Ramp Handrails:**  
Handrails installed in addition to required handrails need not comply with the height requirements stated in Clause (1)(e).
- 3) **Ramp Handrail Exception:**  
The requirement for handrails in Clause (1)(e) need not apply to a ramp serving as an aisle for fixed seating.
- 4) **Ramp Surface:**  
The surfaces of ramps and landings shall
- be hard or resilient where the ramp is steeper than 1 in 15 (see Note A-3.8.3.5.(4)(a)),
  - have a cross slope no steeper than 1 in 50, and
  - where exposed to water, be designed to drain.

**Note A-3.8.3.5.(4)(a)**

Surface of Ramps. Sentence 3.8.3.2.(3) requires that all walking surfaces in an accessible path of travel be stable and firm to limit the effort required by persons using wheelchairs or other mobility aids. Therefore, Sentence 3.8.3.5.(4) requires that hard or resilient flooring be used on the surfaces of steeper ramps. Furthermore, carpet and like materials should not be installed on any ramp.

- 5) **Edge Protection:**  
Ramps and landings not at ground level or adjacent to a wall shall have edge protection consisting of
- a curb not less than 75 mm high, or
  - a raised barrier or rail located not more than 100 mm from the ramp or landing surface.

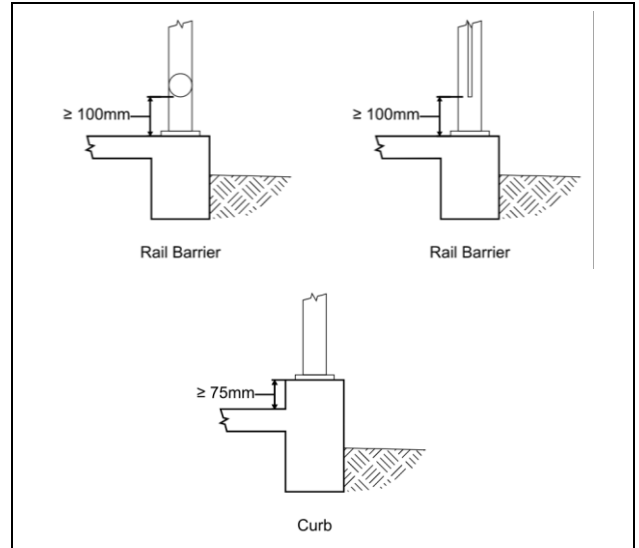

**3.8.3.5.(5) Examples of Types of Edge Protection**

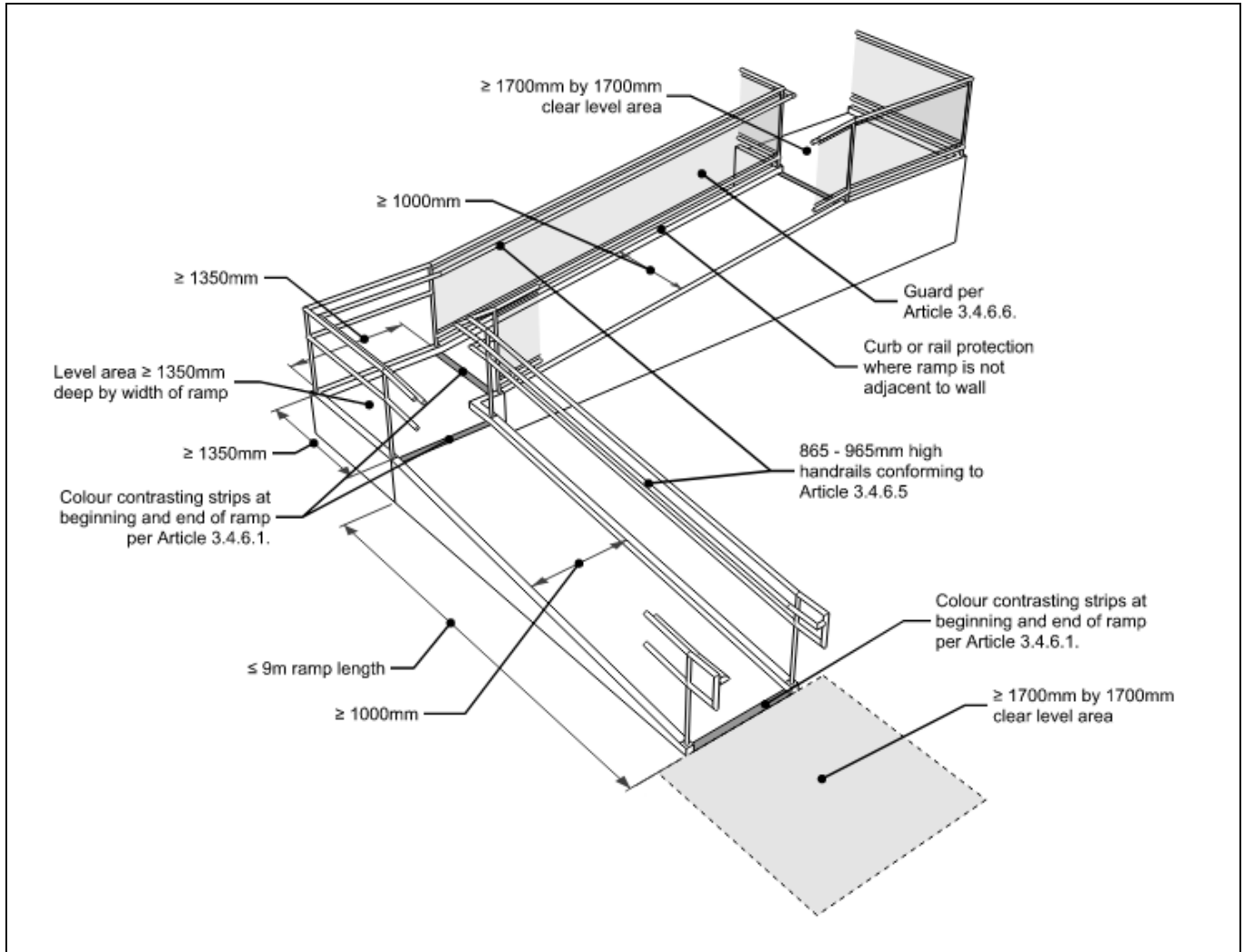

3.8.3.5. Ramp Design

### (3.8.2.7) Application Requirements for Power Door Operators

#### 1) Doors Requiring Power Door Operators:

Except as provided in Sentences (2) and (3), and except for doors provided with hold-open devices, doors equipped with a self-closing device shall be equipped with power door operators complying with Subsection 3.8.3. that allow persons to activate the opening of the doors in the intended direction of travel, where the doors are located

- a) in an entrance referred to in Article 3.8.2.2., including the interior doors of a vestibule where provided,
- b) in an accessible path of travel, between the entrance referred to in Clause (a) and the entrance doors to suites or rooms served by a public corridor or a corridor used by the public (see Note A-3.8.2.7.(1)(b)), and
- c) in an entrance to an accessible washroom.

#### Note A-3.8.2.7.(1)(b)

Power Door Operators for Interior Doors. It is not intended that all doors located in an accessible path of travel be equipped with a power door operator, but rather those that are located within public areas of the building, such as public corridors or corridors used by the public. Doors of suites served by a public area do not need to be equipped with a power door operator.

#### 2) Power Door Operators at Multi Leaf Doors:

Only the active leaf in a multiple leaf door in an accessible path of travel need conform to the requirements of this Article.

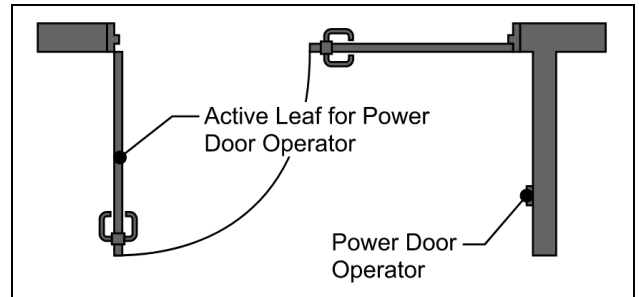

3.8.2.7.(2) Active Leaf for Power Door Operator

#### 3) Power Door Operator at Multiple Doors:

Where more than one doorway is provided at an accessible entrance, only one of them is required to comply with this Article.

#### Note A-3.8.2.7.(3)

Accessible Entrances with Multiple Doorways. In selecting which doorway to equip with a power door operator as required by Sentence 3.8.2.7.(3), consideration should be given to the location of accessible paths of travel, to the ease of access, and to minimizing congestion.

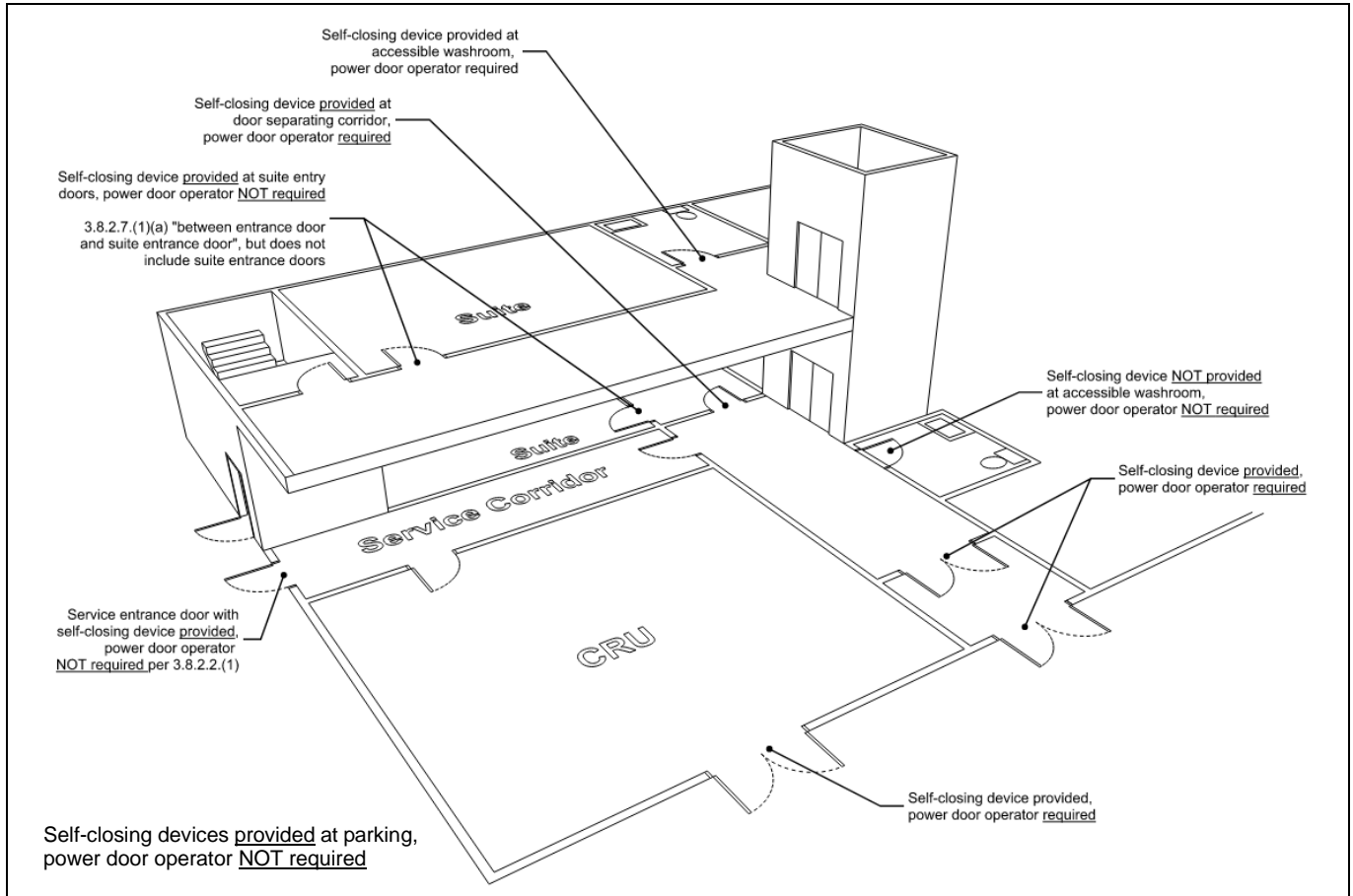

### 3.8.2.7.(1) Doors Requiring Power Door Operators

### (3.8.3.6) Doorways and Doors

- 1) **Application to Doors:**  
Except where stated otherwise, this Article applies to swinging and sliding doors.
- 2) **Door Clear Width:**  
Every doorway that is located in an accessible path of travel shall have a clear width not less than 850 mm
  - a) for swinging doors, when measured from the face of the active leaf, in the open position of 90° to the doorway, to the outside edge of the stop on the door frame, and
  - b) for sliding doors, when measured from the edge of the door, in the open position, to the outside of the stop on the door frame.

(See Note A-3.8.3.6.(2).)

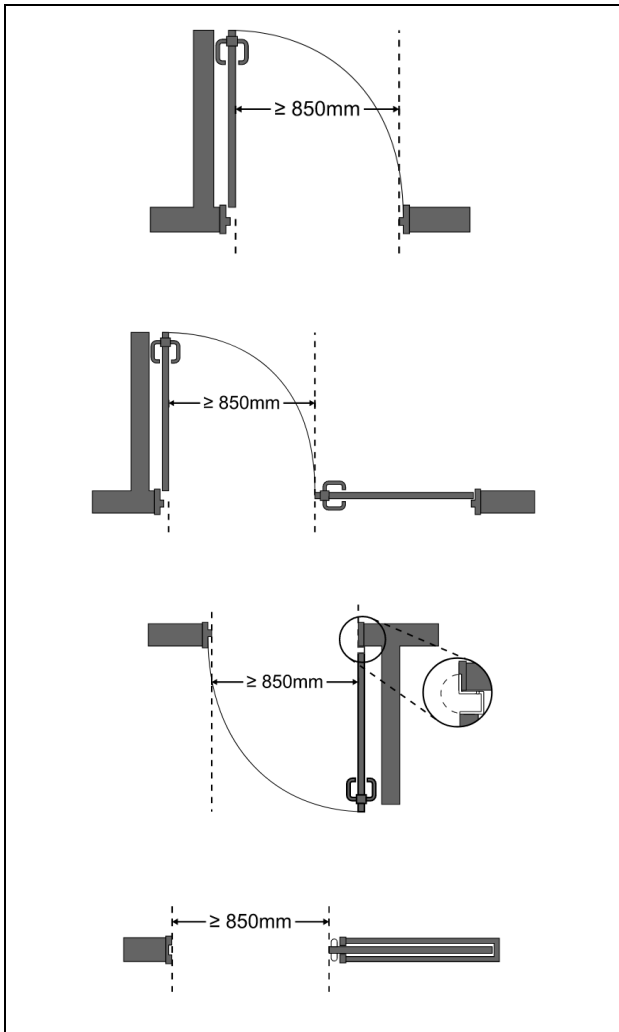

3.8.3.6.(1) Clear Width

#### Note A-3.8.3.6.(2)

Doorway Width. Standard wheelchair width specifications indicate a range of sizes from 584 mm overall to 685 mm overall. Every doorway that is located in an accessible path of travel must have a clear width of not less than 850 mm when the door is in the open position and therefore it is important that this dimension be measured correctly.

It is clear that the door, and to a lesser extent the stop, impinges on the space within the door frame. The clear width of not less than 850 mm is measured from the face of the door in the open position of 90° to the doorway to the outside edge of the stop on the door frame. It is not sufficient just to measure the inside width of the door frame. The hardware selected on sliding doors, such as D-shaped handles, may result in a clear width being substantially less than the inside dimension of the door frame. The clear width for sliding doors is measured from the edge of the open door to the outside edge of the stop on the door frame. Other factors should be taken into account, including the location of door stops other than on the door frame, and the installation of door closers and exit devices, even if they do not span the width of the entire door. The intrusion of a door handle or an exit device into the space is of lesser importance because its height above the floor does not typically obstruct passage using a wheelchair. It is recognized that there are many types of door frames and door mounts, but the overall objective is to maintain a clear width of not less than 850 mm.

- 3) **Door Clear Width in Group C Occupancies:**  
Doorways in a path of travel to at least one bathroom within a suite of residential occupancy shall have a clear width not less than 850 mm when measured in accordance with Sentence (2). (See Note A-3.8.3.6.(3).)

#### Note A-3.8.3.6.(3)

Washrooms in Residential Occupancies (i.e. Group C Occupancies). This requirement ensures that the doorway to the washroom in a hotel or motel suite is at least large enough to accommodate someone using a wheelchair but the washroom is not required to be accessible.

**4) Door operating devices:**

Door-operating devices shall

- a) comply with Clause 3.8.3.8.(1)(b), and
- b) be operable at a height between 900 mm and 1 100 mm above the floor.

(See Note A-3.8.3.6.(4).) (See also Sentence 3.3.1.13.(4) regarding additional devices.)

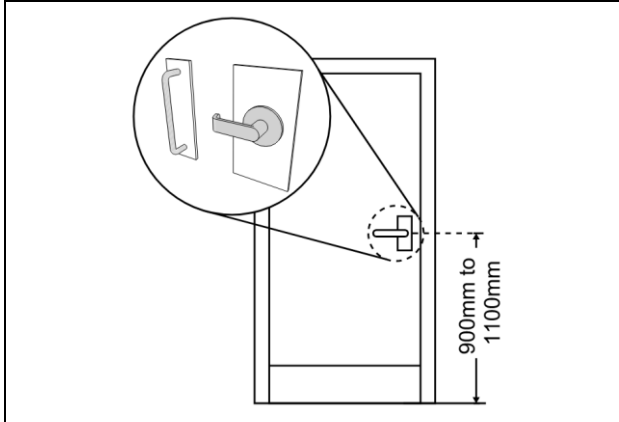

**3.8.3.6.(4) Examples of Accessible Hardware**

**Note A-3.8.3.6.(4)**

**Lever Handles.** Lever handles are usable by most people and will meet the intent of this requirement. Lever handles with an end return towards the door are less prone to catch the clothing of someone passing through the doorway. Large D-shaped handles should be used on sliding doors.

**5) Door Thresholds:**

A threshold for a doorway referred to in Sentences (2) and (3) shall be not more than 13 mm higher than the finished floor surface and shall be bevelled to facilitate the passage of wheelchairs.

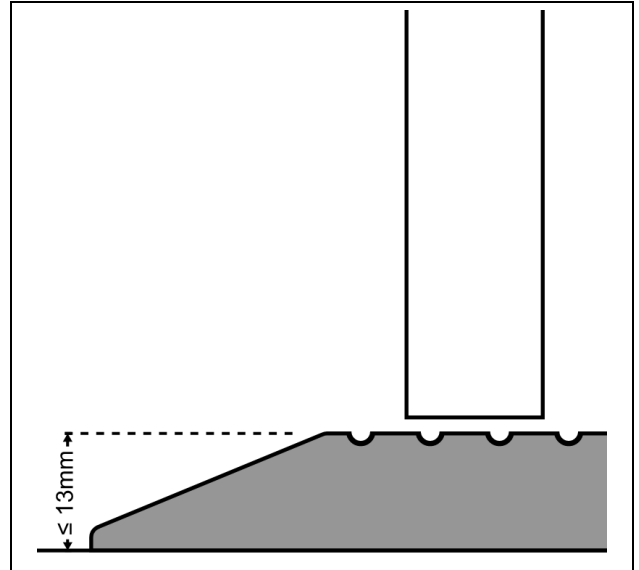

**3.8.3.6.(5) Door Threshold**

**6) Power Door Operators:**

Power door operators required by Sentence 3.8.2.7.(1) shall

- a) activate automatically or through the use of controls that
  - i) are located in an accessible path of travel,
  - ii) are marked with the International Symbol of Access,
  - iii) are located clear of the door swing and not less than 600 mm and no more than 1 500 mm from that door swing,
  - iv) comply with Subclause 3.8.3.8.(1)(a)(iii)
  - v) are operable from a height between 150 mm and 300 mm as well as between 900 mm and 1 100 mm above the floor, and floor
  - vi) are operable by touching or approaching any part of their surface with a fist, arm or foot, and
- b) unless equipped with safety sensors,
  - i) fully open the door in not less than 3 s, and
  - ii) require a force not more than 65 N to stop movement of the door.

(See Note A-3.8.3.6.(6) and (7).)

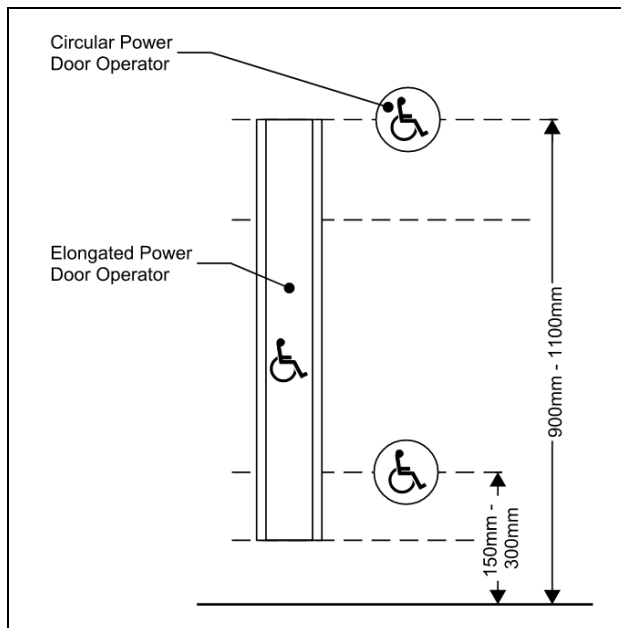

**3.8.3.6.(6) Power Door Operators Heights**

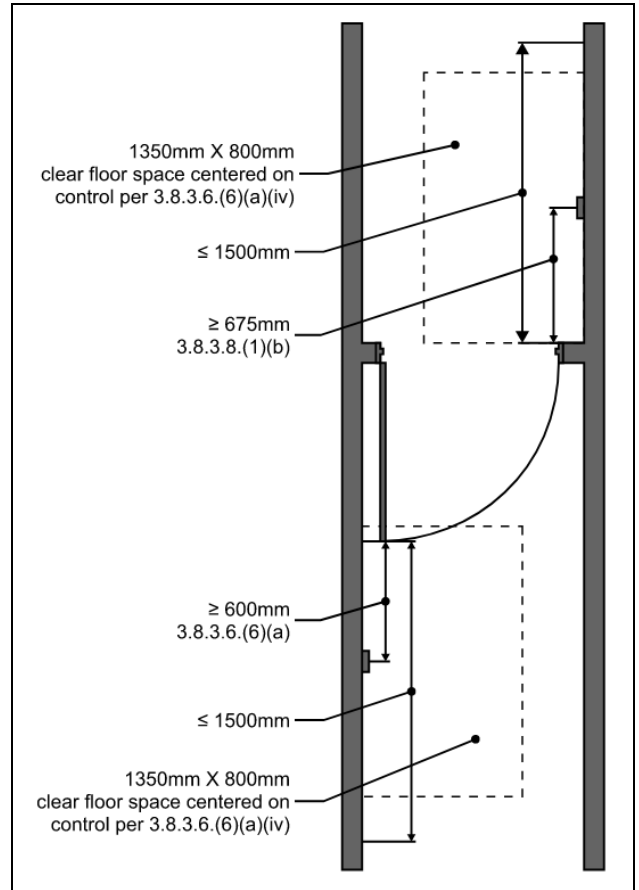

**3.8.3.6.(6) Power Door Operator – Plan View**

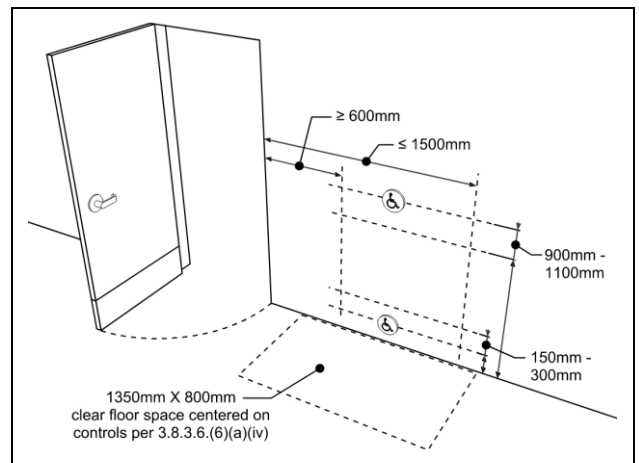

**3.8.3.6.(6) Power Door Operator – 3D**



**7) Cane Detection:**

A cane-detectable guard shall be installed on the hinged side of power-assisted doors that swing open into the path of travel. (See Note A-3.8.3.6.(6) and (7).)

**Note A-3.8.3.6.(6) & (7)**

**Doors with Power Operators.** Doors equipped with a power operator actuated by a pressure plate identified with the International Symbol of Access or, where security is required, by a key, card or radio transmitter, and that can otherwise be opened manually, meet the intent of the requirement. The location of these actuating devices should ensure that a wheelchair will not interfere with the operation of the door once it is actuated. Swinging doors equipped with power operators which are actuated automatically and open into passing pedestrian traffic should be provided with a guard or other device designed to prevent pedestrians from stepping in the swing area of the door. These guards or devices should be detectable by blind persons. For example, inverted U-shaped guards should have an additional rail at a height not more than 680 mm so that it is detectable by the long cane. These doors should also have a device (mat or other sensor) on the swing side to prevent the door from opening if someone is standing in the swing area.

**8) Door Opening Forces:**

Except as provided in Sentence (9) and except for a door with a power door operator complying with Sentence (6), when unlatched, a door in an accessible path of travel shall open when the force applied to the handle, push plate or latch-releasing device is not more than

- 38 N in the case of an exterior swinging door,
- 22 N in the case of an interior swinging door, or
- 22 N in the case of a sliding door.

**9) Exception to Latch Release Device Forces:**

Sentence (8) does not apply to a door at the entrance to a dwelling unit, or where greater forces are required in order to close and latch the door against the prevailing difference in air pressure on opposite sides of the door. (See Note A-3.8.3.6.(9).)

**Note A-3.8.3.6.(9)**

**Air Pressure Differences.** Differences in air pressure on opposite sides of a door may be due to the operation of mechanical systems such as those associated with smoke control. So-called "stack action" in buildings in winter can also cause differential pressures due to the buoyancy of warm air. Stack action is usually most noticeable between stairwells and the remainder of the building, and at the entrances to buildings; the taller the building, the greater the effect. Doors with automatic closers have to operate with sufficient opening force to allow the return action to overcome the differential pressure.

**10) Door Closing Speed**

Except for a door at the entrance to a dwelling unit, a closer for an interior door in an accessible path of travel shall have a closing period of not less than 3 s measured from when the door is in an open position of 70° to the doorway, to when the door reaches a point 75 mm from the closed position, measured from the leading edge of the latch side of the door. (See Note A-3.8.3.6.(10).)

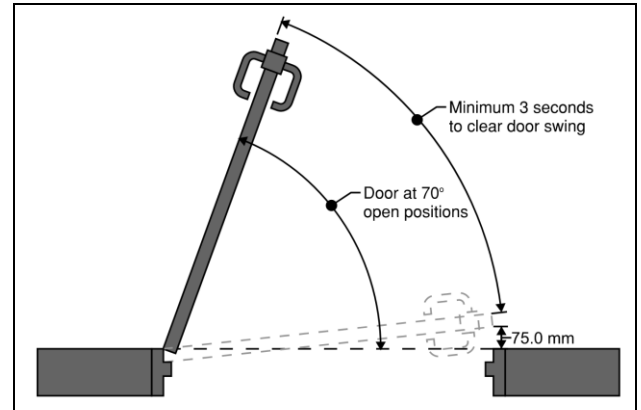
**3.8.3.6.(10) Door Closing Speed****Note A-3.8.3.6.(10)**

**Delayed Action on Door Closers.** In some circumstances, closers with a delay feature which keeps the door open for several seconds before it begins to close might be desirable. However, closers with this feature have limited back-check, a feature of a normal door closer where resistance to opening increases as the door reaches the full arc of swing. Doors equipped with a delayed action closer are therefore more susceptible to damage should the door be opened with too much force or should someone try to force it closed, thinking the closer has failed to operate. Delayed action closers are not recommended for such occupancies as schools.

**11) Clearance Area Beside Door**

Unless equipped with a power door operator complying with Sentence (6), a swinging door in an accessible path of travel shall have a clear space on the latch side extending the height of the doorway and not less than

- 600 mm beyond the edge of the door opening if the door swings toward the approach side, and
- 300 mm beyond the edge of the door opening if the door swings away from the approach side.

(See Note A-3.8.3.6.(11).)

**Note A-3.8.3.6.(11)**

**Clearance at Doorways.** Sufficient clearance must be provided on the latch side of doors for a user to operate the door-opening mechanism and open the door without interference from the wheelchair. This is particularly important for a door swinging towards the approach side. See Figure A-3.8.3.6.(11).

**12) Doors in Series:**

A vestibule located in an accessible path of travel shall be arranged to allow the movement of wheelchairs between doors and shall provide a distance between 2 doors in series of not less than 1 350 mm plus the width of any door that swings into the space in the path of travel from one door to another.

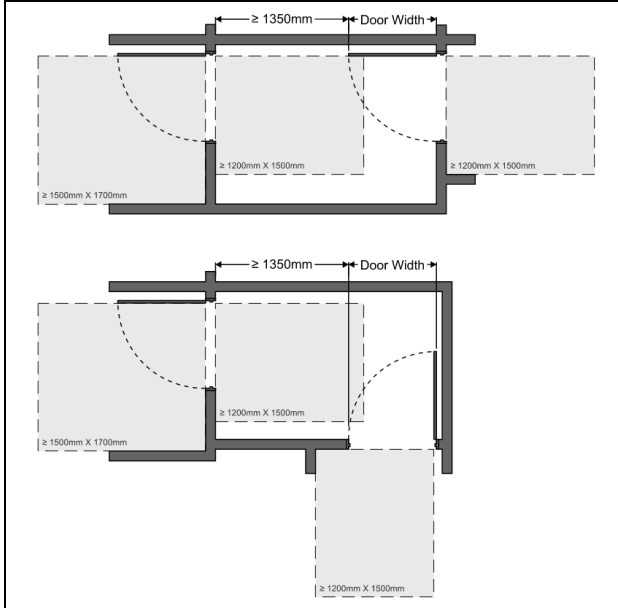
**3.8.3.6.(12) Doors in Series****13) Door Leaf Activity:**

Only the active leaf in a multiple-leaf door in an accessible path of travel need conform to the requirements of this Article.

**14) Clear Area at Door on Pull Side:**

Except as provided in Clause 3.8.3.5.(1)(c) and Sentence (16), the clear floor space on the pull side of a swinging door in an accessible path of travel shall be level within a rectangular area of not less than 1 700 mm by 1 500 mm measured from the hinged side of the door. (See Note A-3.8.3.6.(14) to (16).)

**15) Clear Area at Door on Push Side:**

Except as provided in Clause 3.8.3.5.(1)(c) and Sentence (16), the clear floor space on the push side of a swinging door and on each side of a sliding door in an accessible path of travel shall be level within a rectangular area

- whose dimension parallel to the closed door is not less than 1 200 mm, and
- whose dimension perpendicular to the closed door is not less than 1 500 mm.

(See Note A-3.8.3.6.(14) to (16).)

**16) Clear Area at Door with Power Door Operator**

Where a door referred to in Sentences (14) and (15) is equipped with a power door operator complying with Sentence (6), the width of the clear floor space parallel to the closed door is permitted to be reduced to not less than 1 000 mm. (See Note A-3.8.3.6.(14) to (16).)

**Note A-3.8.3.6.(14) & (16)**

Minimum Clear Floor Space at Doors in an Accessible Path of Travel. Power door operators serving doorways with a reduced width of the clear floor space should be operational at all times when the space is intended to be occupied.

**17) Door Contrast**

Except for facilities for persons with cognitive disabilities such as dementia, doorways leading from a public corridor or a corridor used by the public that provide access to a public area or an exit shall be provided with a door or door frame that has a readily apparent visual contrast with adjacent wall surfaces. (See Note A-3.8.3.6.(17).) (See also Note A-3.4.6.11.(4).)

**Note A-3.8.3.6.(17)**

Public Area. In the context of Sentence 3.8.3.6.(17), "public area" is intended to refer to a suite, room or area that is generally open to building occupants, such as a cafeteria, lounge room, washroom or office, but is not intended to include a space such as a janitor's room, service space or service room.

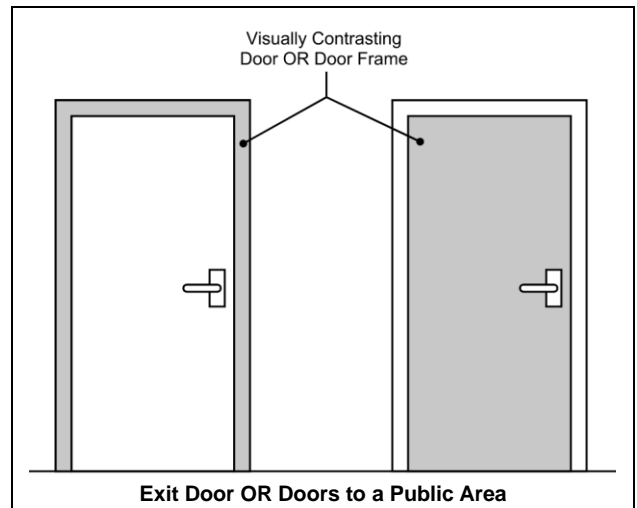
**3.8.3.6.(17) Door Contrast**

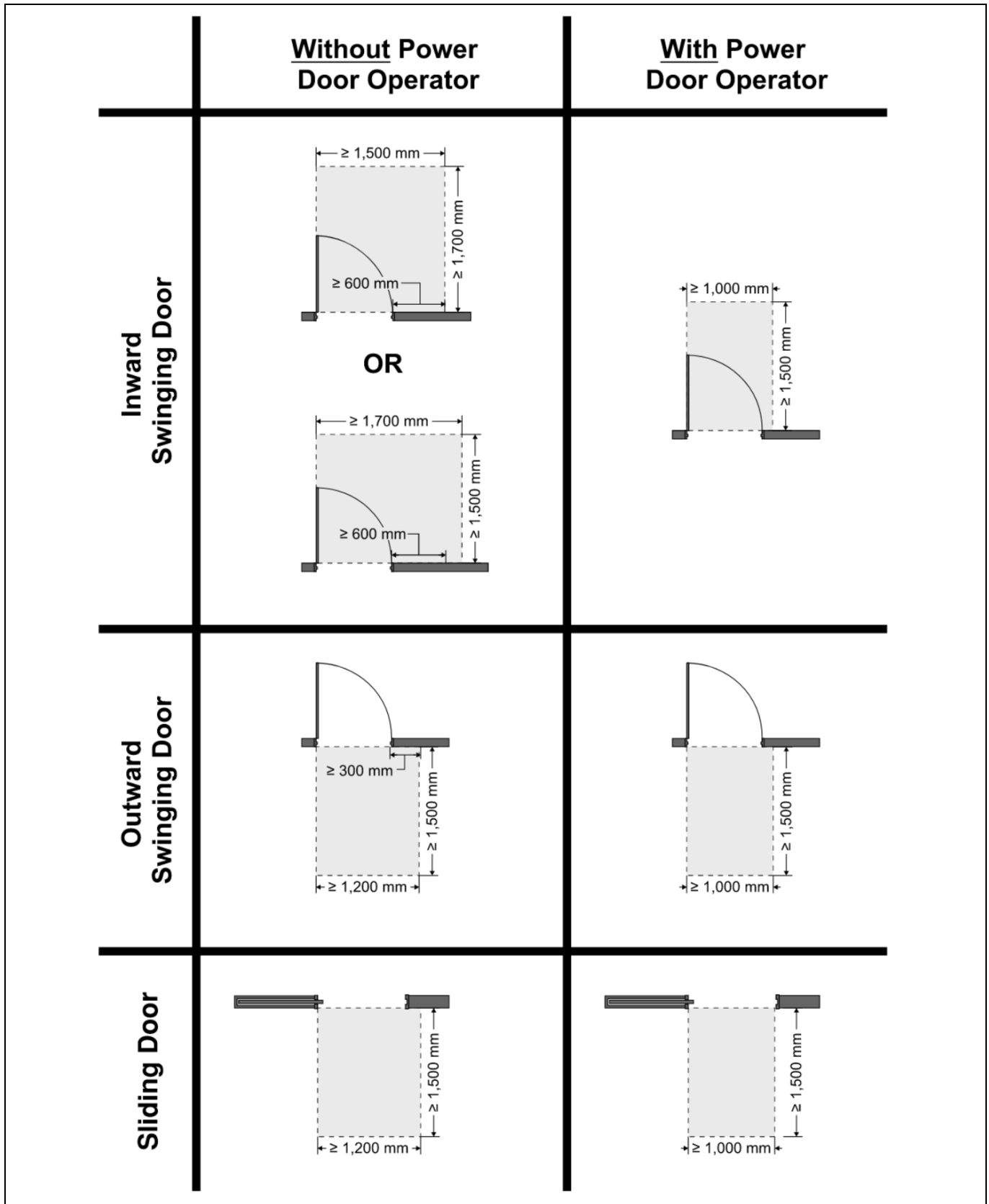

3.8.3.6.(14) to (16) Required Clear Floor Space at Doors

### (3.8.3.7) Passenger Elevating Devices

#### 1) Lift & Elevating Device Design Requirements

A passenger-elevating device referred to in Article 3.8.2.3. located in an accessible path of travel shall

- a) conform to
  - i) Appendix E of ASME A17.1/CSA B44, "Safety Code for Elevators and Escalators," or
  - ii) CSA B355, "Platform lifts and stair lifts for barrier-free access,"
- b) have a clear floor space not less than 1 500 mm long by 1 000 mm wide, and
- c) have entry doors or gates
  - i) providing a clear width not less than 850 mm in the open position if located on the short side of the passenger-elevating device, or
  - ii) providing a clear width not less than 1 000 mm in the open position if located at either end of the long side of the passenger-elevating device.

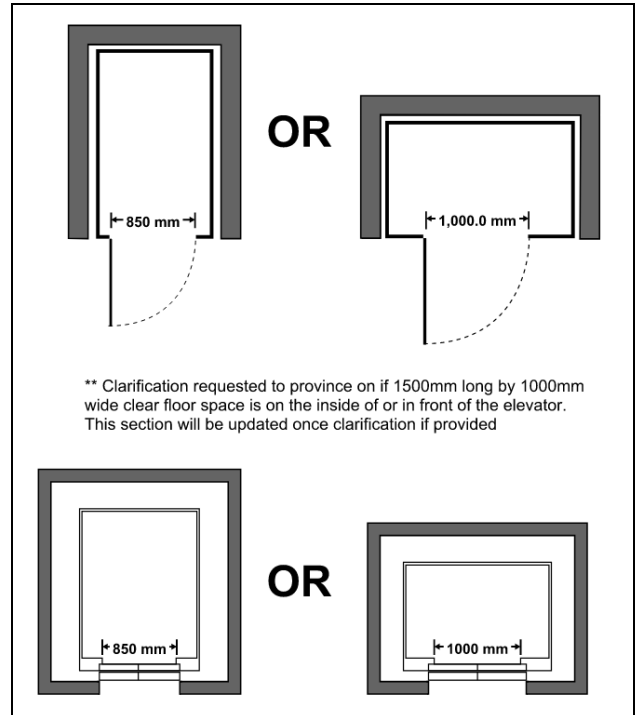

**3.8.3.7. Clear Floor Space at Passenger Elevating Device**

### (3.3.1.19.) Tactile Attention Indicators

#### 1) Required Tactile Locations:

Except as provided in Sentence (2), tactile attention indicators complying with Clauses 4.3.5.3.1, 4.3.5.3.3 and 4.3.5.3.4 of CSA B651, "Accessible design for the built environment," shall be installed

- at the top of flights of stairs that are unenclosed, and
- at drop-off edges with a change in elevation greater than 300 mm that are unprotected by a guard.

(See Note A-3.3.1.19.(1).)

#### Note A-3.3.1.19.(1)

Tactile Attention Indicators at Unenclosed Stairs and at Drop-off Edges. Stairs in open spaces, stairs from mezzanines, and stairs that are not separated from the floor area by an element, such as a door or gate, are examples of stairs that are unenclosed. Transit platforms and the edges of a reflecting pool are examples of locations with drop-off edges where tactile attention indicators should be installed.

#### 2) Exceptions to Tactile Locations

Sentence (1) does not apply to service spaces, bleachers addressed in Subsection 3.3.2., stages, loading docks, industrial occupancies, within dwelling units, and to stairs and drop-off edges serving not more than two dwelling units.

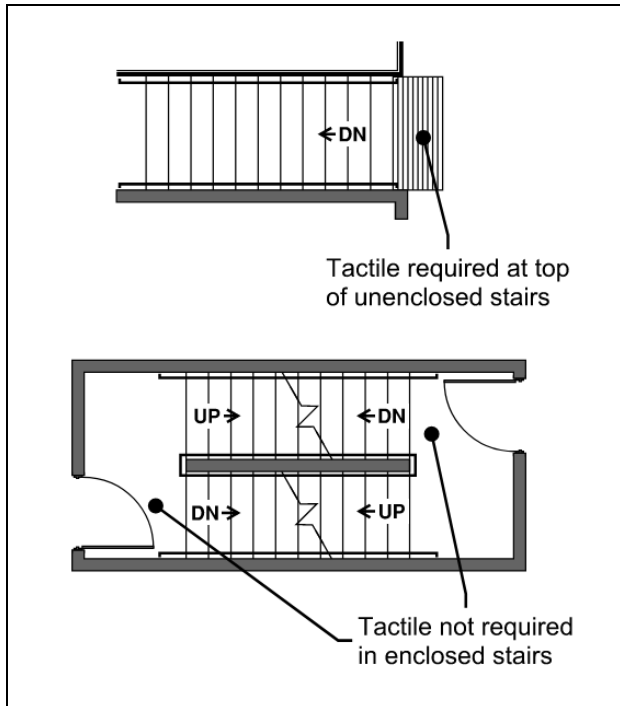

3.3.1.19.(2) Tactile Locations

#### CSA B651-18 Clauses 4.3.5.3.1, 4.3.5.3.3 and 4.3.5.3.4

##### 4.3.5.3.1. Configuration

A tactile attention indicator surface shall be composed of truncated domes

- with a height of between 4 mm and 5 mm;
- with the top diameter between 12 and 25 mm and the base diameter 10 mm ± 1 mm greater than the top diameter;
- arranged in a square grid; and
- with a centre-to-centre distance of adjacent domes complying with Table 2

Table 2  
Dome diameter and spacing combinations  
(See Clause 4.3.5.4.1.)

Top surface diameter, mm	Base surface diameter, mm, ± 1 mm	Centre-to-centre distance between domes, mm
12	22	42-61
15	25	45-63
18	28	48-65
20	30	50-68
25	35	55-70

##### 4.3.5.3.3. Installation

When a tactile attention indicator surface is used to indicate a hazard, it shall be installed along the full width of the hazard

- to a depth between 600 and 650mm; and
- with one side against the edge of the hazard, unless otherwise indicated in this Standard.

##### 4.3.5.3.4. Luminance contrast

When a tactile attention indicator surface is used to indicate a hazard, it shall

- have a luminance contrast of at least 50% with the adjacent surface using the Michelson Contrast formula (see Clause 4.3.5.3.5; or
- if yellow, have a contrast of at least 40% with the surrounding surface. If this level is not achievable, the necessary contrast may be provided by means of an adjoining continuous luminance contrasted band at least 100mm wide installed adjacent to the indicator surface

##### 4.3.5.3.4. Luminance contrast

When a tactile attention indicator surface is used to indicate a hazard, it shall

##### 4.3.5.3.5. Calculation of the luminance contrast value

The luminance contrast value (%) shall be calculated using the following formula, known as Michelson Contrast,  $C_M$ :

$$C_M = (L_1 - L_2) / (L_1 + L_2) \times 100$$

where

$L_1$  = the value of luminance on a lighter surface, expressed in  $cd/m^2$ ;

$L_2$  = the value of luminance on a darker surface, expressed in  $cd/m^2$

When luminance values are not available, but CIE Y values are available, the values  $Y_1$  and  $Y_2$  may be substituted for  $L_1$  and  $L_2$ . Note that the CIE Y value is identical to the LRV.

When the CIE Y values or the LRVs of the two surfaces to be compared are known, these values may be used to determine the luminance contrast. Otherwise, a measurement of luminance or reflectance shall be used to determine the luminance contrast. For measurement methods, see IESNA HB-9-00 (referenced in Clause A.4 of this Standard)

# 2 PLUMBING FACILITIES



### (3.8.2.8) Application Requirements for Plumbing Facilities

#### 1) Universal Washroom:

Except as permitted by Sentence (3) and (16), at each location where washrooms are provided in a storey to which an accessible path of travel is required in accordance with Article 3.8.2.3., at least one universal washroom complying with Subsection 3.8.3. shall be provided. (See Note A-3.8.2.8.(1) to (4).)

#### 2) Accessible Water Closet Stall:

Except as permitted by Sentence (3), where more than two water closets or a combination of more than one water closet and one urinal are provided in a washroom located in a storey to which an accessible path of travel is required in accordance with Article 3.8.2.3., at least one water-closet stall shall be accessible in accordance with Subsection 3.8.3. (See Note A-3.8.2.8.(1) to (4).)

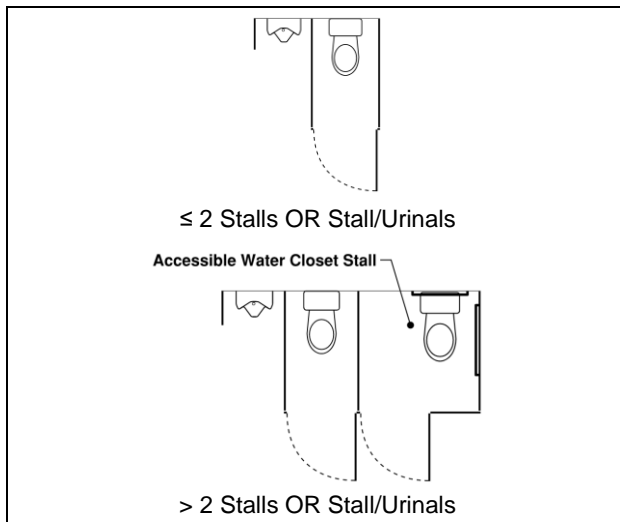

**3.8.2.8.(2) Number of Water Closets or Urinals Triggering Accessible Water Closet Stall**

#### 3) Accessible Washroom Exceptions:

Except as required by Article 3.8.2.13., washrooms located within a suite of residential occupancy or a suite of care occupancy need not conform to the requirements of Sentence (1) or (2). (See Note A-3.8.2.8.(1) to (4).)

#### 4) Universal Washroom Location Exception:

In a building in which water closets are required in accordance with Subsection 3.7.2., at least one universal washroom shall be provided in the entrance storey, unless

- an accessible path of travel is provided to a universal washroom elsewhere in the building, or
- the water closets required by Subsection 3.7.2. are for dwelling units only.

(See Note A-3.8.2.8.(1) to (4).)

#### Note A-3.8.2.8.(1) to (4)

Accessible and Universal Washrooms. A universal washroom is an accessible space providing privacy for one person and their care attendant(s), regardless of their gender. It is intended that a universal washroom be available in close proximity to each bank of washrooms in a floor area. In the case where only one water closet is provided, a universal washroom would satisfy the requirement of Sentence 3.8.2.8.(1).

#### 5) Accessible Water Closet Stall:

At least one water-closet stall or enclosure in a washroom required to be accessible shall comply with Subsection 3.8.3.

#### 6) Limited Mobility Urinals:

Where urinals are provided in an accessible washroom, at least one urinal for persons with limited mobility conforming to Subsection 3.8.3. shall be provided for every 10 urinals.

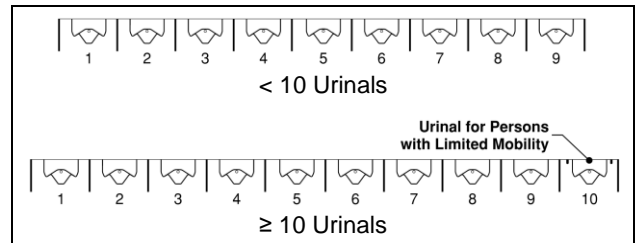

**3.8.2.8.(6) Number of Urinals Triggering Limited Mobility Urinal**

#### 7) Limited Mobility Water Closet Stalls:

Where water-closet stalls are provided in an accessible washroom, at least one stall for persons with limited mobility conforming to Subsection 3.8.3. shall be provided for every 10 stalls.

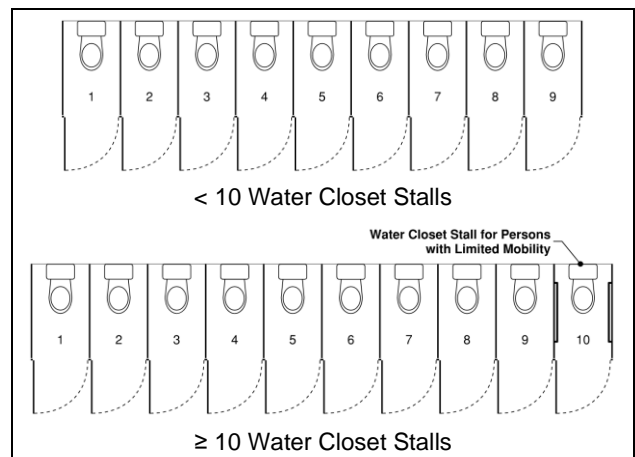

**3.8.2.8.(7) Number of Stalls Triggering Limited Mobility Water Closet Stall**

- 8) **Lavatory:**  
An accessible washroom shall be provided with a lavatory that complies with Subsection 3.8.3.
- 9) **Mirrors:**  
Where mirrors are provided in an accessible washroom, at least one mirror shall comply with Subsection 3.8.3.
- 10) **Drinking Fountains:**  
At each location where one or more drinking fountains are provided, at least one of them shall comply with Subsection 3.8.3.
- 11) **Water Bottle Filling Station:**  
At each location where one or more water-bottle filling stations are provided, at least one of them shall comply with Subsection 3.8.3.
- 12) **Shower:**  
Except within a suite of care occupancy or a suite of residential occupancy, where showers are provided in a building, at least one shower stall in each group of showers shall comply with Subsection 3.8.3.

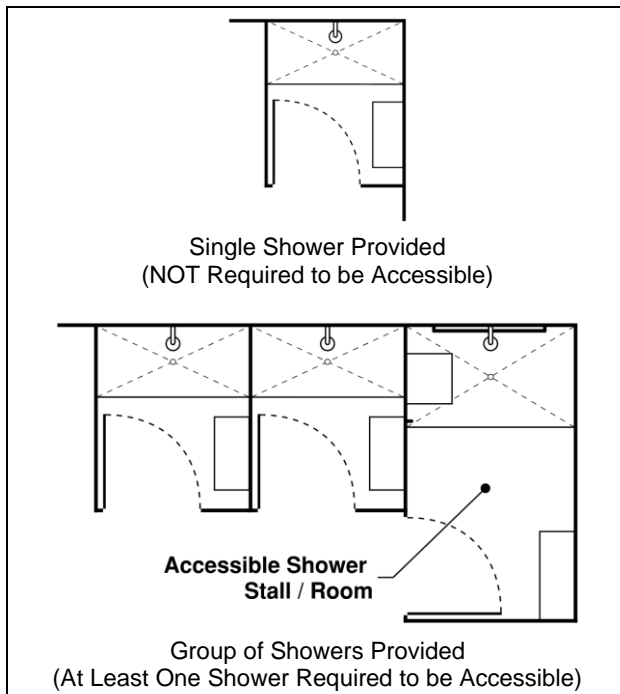

**3.8.2.8.(12) Number of Showers Triggering Accessible Shower**

- 13) **Universal Dressing & Shower Room:**  
At each location where a showering facility is provided for use by the general public or customers, or as part of a common-use area for employees, at least one universal dressing and shower room conforming to Subsection 3.8.3. shall be provided. (See Note A-3.8.2.8.(13).)

**Note A-3.8.2.8.(13)**

Universal Dressing and Shower Rooms. A universal dressing and shower room is an accessible space that contains a shower and a space for dressing for one person and their care attendant(s) and provides privacy, regardless of gender.

It is intended that a universal dressing and shower room be available within close proximity to each bank of showers in a floor area. In cases where only one shower is provided, a universal dressing and shower room would satisfy the requirement.

- 14) **Bathtub:**  
Where a bathtub is installed in a suite of residential occupancy required to be accessible, it shall comply with Subsection 3.8.3.
- 15) **Adult Change Table:**  
In buildings containing Group A, Group B, Division 2 or Group E major occupancies where at least one of these major occupancies has an occupant load of more than 500, at least one universal washroom on the storey on which the main accessible entrance to the building is located shall incorporate an accessible change space conforming to Subsection 3.8.3. (See Note A-3.8.2.8.(15).)

**Note A-3.8.2.8.(15)**

Accessible Change Spaces. The intent of Sentence 3.8.2.8.(15) is to ensure that in large major occupancies, such as large shopping malls, public pools and libraries, occupants who may need assistance with personal hygiene will have access to an accessible change space that can be found in a consistent location. Universal washrooms containing an accessible change space should be located so that they are available to the public when the large major occupancy is occupied. A suitable location could be in the lobby of a building housing the large major occupancy that remains open during that major occupancy's business hours, for example.

- 16) **Altered Grab Bars:**  
In occupancies or parts of occupancies designed to be accessible and used predominantly by children, in patient areas in treatment occupancies, and in resident areas in care occupancies, it is permissible to design and locate plumbing fixtures and grab bars differently than described in Subsection 3.8.3. to accommodate the special needs of children, patients, residents, and care providers.



**(3.8.3.10) Drinking Fountains****3.8.2.8.(10) Drinking Fountains**

At each location where one or more drinking fountains are provided, at least one of them shall comply with Subsection 3.8.3.

- 1) **Drinking Fountain Controls:**  
Drinking fountains required by Sentence 3.8.2.8.(10) shall be equipped with controls that
  - a) activate automatically, or
  - b) comply with Clause 3.8.3.8.(1)(b) and are located on the front or on both sides of the fountain.
- 2) **Drinking Fountain Design:**  
Where drinking fountains referred to in Sentence (1) are located in a storey where an accessible path of travel is required, they shall
  - a) be located along the accessible path of travel,
  - b) have a minimum clear floor space of 800 mm by 1350 mm in front of them,
  - c) where they have frontal access, provide a knee clearance in accordance with Clause 3.8.3.16.(1)(e), and
  - d) have a spout that
    - i) is located near the front of the unit, at a height between 750 mm and 915 mm above the floor, and
    - ii) directs water flow in a trajectory that is nearly parallel to the front of the unit, at a height not less than 100 mm.

(See Sentences 3.3.1.8.(2) and (3) on horizontal projections.)

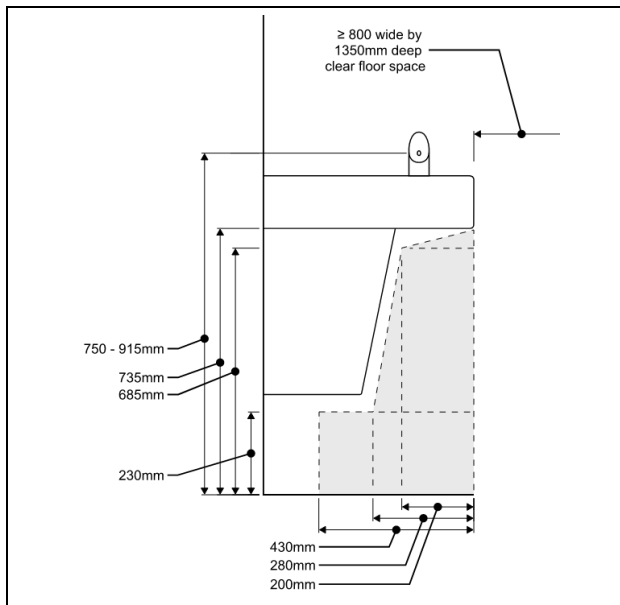

**3.8.3.10. Drinking Fountain**

**(3.8.3.11) Water Bottle Filling Stations****3.8.2.8.(11) Water Bottle Filling Station**

At each location where one or more water-bottle filling stations are provided, at least one of them shall comply with Subsection 3.8.3.

- 1) **Water Bottle Filling Station Controls:**  
Water-bottle filling stations required by Sentence 3.8.2.8.(11) shall be equipped with controls that
  - a) activate automatically, or
  - b) comply with Clause 3.8.3.8.(1)(b).
- 2) **Water Bottle Filling Station Design:**  
Water-bottle filling stations required by Sentence 3.8.2.8.(11) that are located in a storey where an accessible path of travel is required shall
  - a) be located along the accessible path of travel,
  - b) have a clear floor space of 800 mm by 1350 mm in front of them,
  - c) where they have frontal access, provide a knee clearance in accordance with Clause 3.8.3.16.(1)(e),
  - d) be operable at a height of not more than 1200 mm above the floor, and
  - e) be equipped with controls that
    - i) activate automatically, or
    - ii) comply with Sentence 3.8.3.8.(1).

(See Sentences 3.3.1.8.(2) and (3) on horizontal projections.)

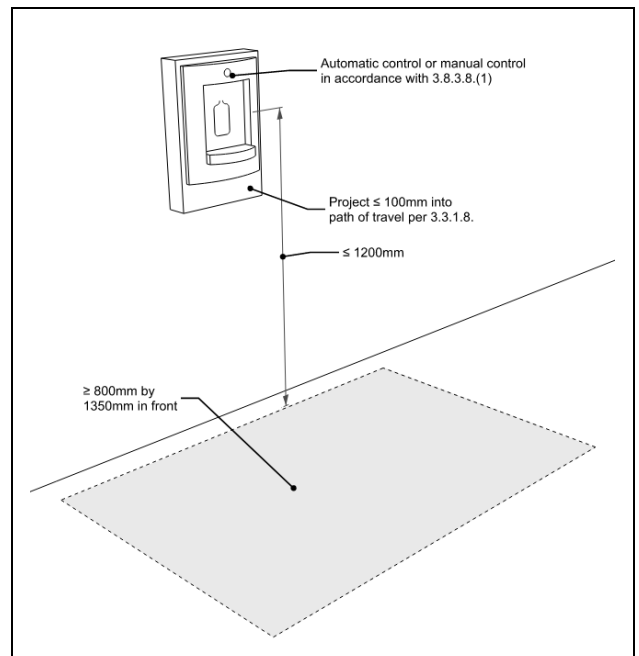

**3.8.3.11. Water Bottle Filling Station**

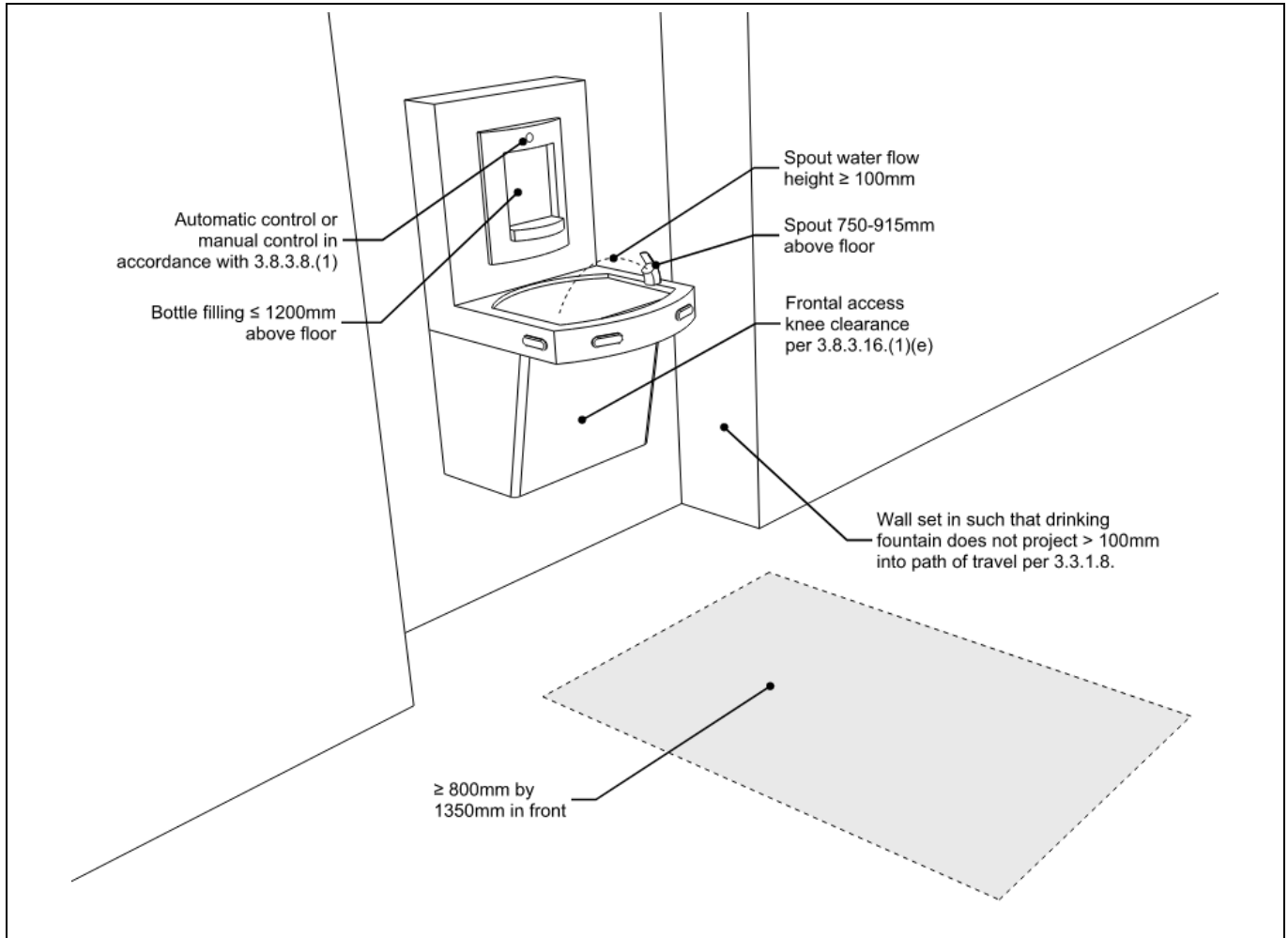

3.8.3.10. & 3.8.3.11. Drinking Fountain & Water Bottle Filling Station

### (3.8.3.12) Accessible Water-Closet Stalls

#### 3.8.2.8.(2) Accessible Water Closet Stall

Except as permitted by Sentence (3), where more than two water closets or a combination of more than one water closet and one urinal are provided in a washroom located in a storey to which an accessible path of travel is required in accordance with Article 3.8.2.3., at least one water-closet stall shall be accessible in accordance with Subsection 3.8.3. (See Note A-3.8.2.8.(1) to (4).)

#### 1) Accessible Water Closet Stall Design Requirements

Water-closet stalls and enclosures required by Sentence 3.8.2.8.(5) shall

- a) be not less than 1 500 mm wide by 1 500 mm deep,
- b) have a clear lateral transfer space adjacent to the water closet that
  - i) is at least 1 500 mm long, measured from the wall behind the water closet, and
  - ii) is at least 900 mm wide, measured from the closest edge of the water closet seat, (see Note A-3.8.3.12.(1)(b))

#### Note A-3.8.3.12.(1)(b)

Lateral Transfer Space on Alternate Sides of Water Closet. The lateral transfer space required by Clause 3.8.3.12.(1)(b) should be provided on the right side in one accessible stall or universal washroom and on the left side in another so that users can choose the facility with a transfer space on the side they prefer to use.

- c) have a clear floor space of 1 700 mm by 1 700 mm in front of the accessible stall,
- d) be equipped with a door that
  - i) can be latched from the inside with a mechanism located 900 mm to 1 100 mm above the floor that conforms to Clause 3.8.3.8.(1)(b),
  - ii) is aligned with either the transfer space adjacent to the water closet or with a clear floor space not less than 1 700 mm by 1 700 mm within the stall,
  - iii) provides a clear opening not less than 850 mm wide when it is open, measured in accordance with Sentence 3.8.3.6.(2),
  - iv) is self-closing so that, when at rest, the door is ajar by not more than 50 mm beyond the jamb,
  - v) swings outward, unless there is sufficient floor space within the stall for the door to swing inward in addition to a clear floor space of at least 800 mm by 1 350 mm (see Note A-3.8.3.12.(1)(d)(v)),
  - vi) where the door swings outward, is provided with a horizontal, D-shaped, visually contrasting door pull not less than 140 mm long located on the inside such that its midpoint is 200 mm to 300 mm from the hinged side of the door and 900 mm to 1100 mm above the floor (see Note A-3.8.3.12.(1)(d)(vi)), and

vii) is provided with a horizontal, D-shaped, visually contrasting door pull not less than 140 mm long located on the outside such that its midpoint is 120 mm to 220 mm from the latch side and 900 mm to 1100 mm above the floor,

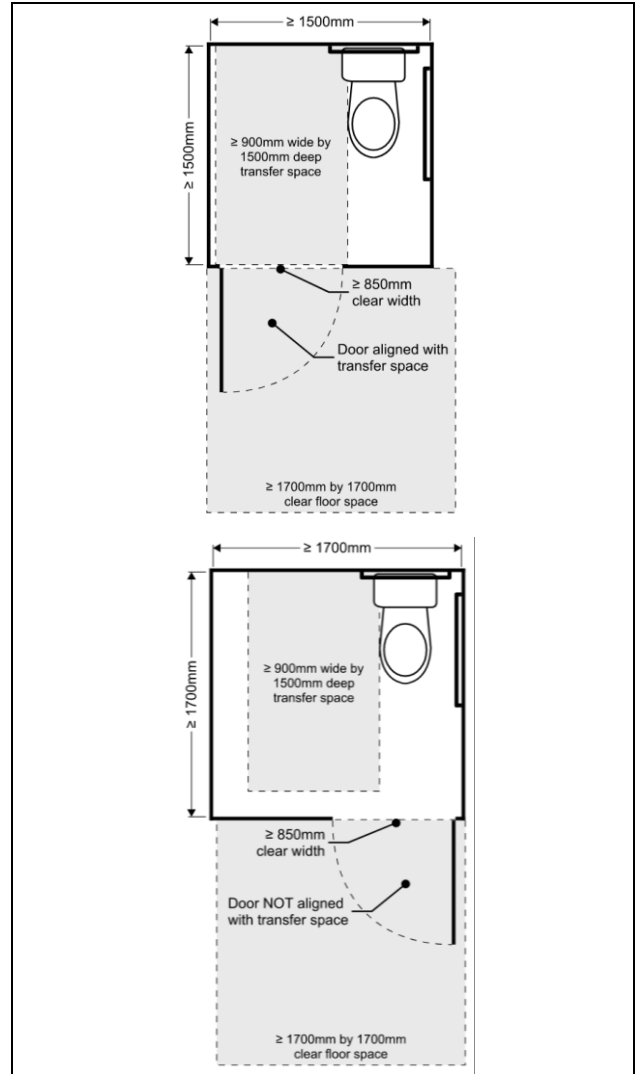

3.8.3.12. Stall Size & Clear Floor Space

#### Note A-3.8.3.12.(1)(d)(v)

Water-closet Stalls. Doors to water-closet stalls for persons with physical disabilities should swing outward, preferably against a side wall.

#### Note A-3.8.3.12.(1)(d)(vi)

Door Pulls. The door pull should consist of a D-shaped handle mounted horizontally. The centre lines are the lines drawn through the long axis and the short axis of the handle. The midpoint of the handle must be located horizontally at 200 to 300 mm from the hinged side of the door and vertically at 900 to 1 100 mm above the finished floor surface.

- e) have a water closet located so that the distance between the centre line of the fixture and the wall on one side is 460 mm to 480 mm,
- f) be equipped with an L-shaped grab bar that
  - i) is mounted on the side wall closest to the water closet,
  - ii) has horizontal and vertical components not less than 760 mm long mounted with the horizontal component 750 mm to 850 mm above the floor and the vertical component 150 mm in front of the water closet (see Note A-3.8.3.12.(1)(f)(ii)), and
  - iii) complies with Article 3.7.2.7.,
- g) be equipped with either one grab bar at least 600 mm long and centred over the water closet, or two grab bars at least 300 mm long and located either side of the flush valve, that
  - i) conform to Article 3.7.2.7.,
  - ii) are mounted on the rear wall, and
  - iii) are mounted at the same height as the grab bar on the side wall or 100 mm above the top of the attached water tank, if applicable,
- h) be equipped with a coat hook mounted not more than 1 200 mm above the floor on a side wall and projecting not more than 50 mm from the wall, and
- i) be equipped with a toilet paper dispenser mounted on the side wall closest to the water closet such that
  - i) the bottom of the dispenser is 600 mm to 800 mm above the floor, and
  - ii) the closest edge of the dispenser is not more than 300 mm from the front of the water closet.

**Note A-3.8.3.12.(1)(f)(ii)**

Additional Grab Bars. It is the designer's prerogative to exceed the minimum requirements found in this Code and specify the installation of additional grab bars in other locations. These additional grab bars may be of different configurations and can be installed in other orientations.

- g) be equipped with either one grab bar at least 600 mm long and centred over the water closet, or two grab bars at least 300 mm long and located either side of the flush valve, that
  - i) conform to Article 3.7.2.7.,
  - ii) are mounted on the rear wall, and
  - iii) are mounted at the same height as the grab bar on the side wall or 100 mm above the top of the attached water tank, if applicable,

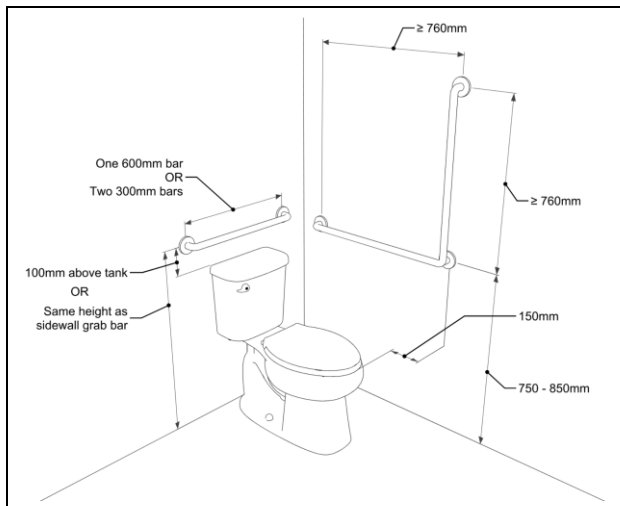

**3.8.3.12. Water Closet Grab Bars**

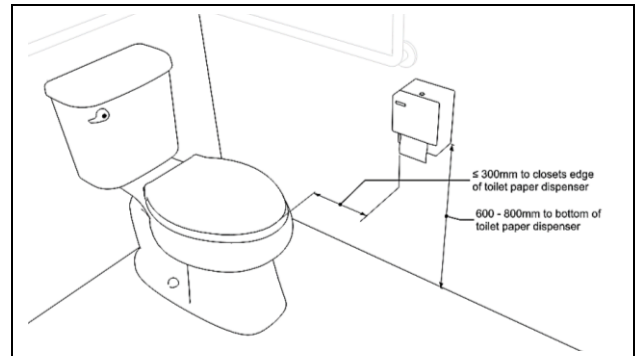

**3.8.3.12. Toilet Paper Dispenser**

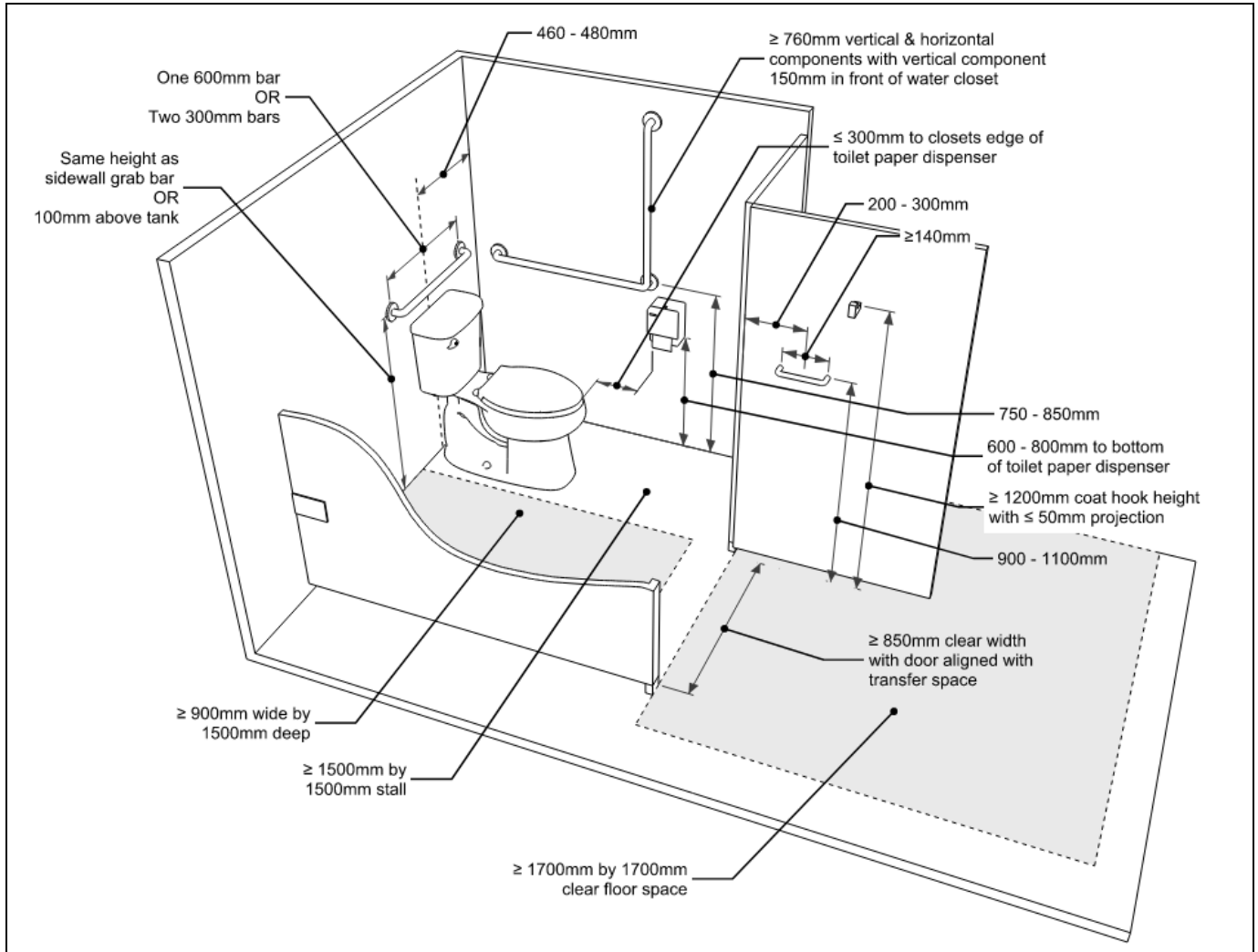

3.8.3.12. Water Closet Stall Requirements

### (3.8.3.13) Universal Washroom

#### 3.8.2.8.(1) Universal Washroom

Except as permitted by Sentence (3) and (16), at each location where washrooms are provided in a storey to which an accessible path of travel is required in accordance with Article 3.8.2.3., at least one universal washroom complying with Subsection 3.8.3. shall be provided. (See Note A-3.8.2.8.(1) to (4).)

#### 1) Universal Washroom Design Requirements

A universal washroom shall  
(See Note A-3.8.3.13.)

- c) be served by an accessible path of travel,
- d) have a door complying with Article 3.8.3.6. that
  - i) has a latch-operating mechanism located 900 mm to 1 100 mm above the floor that complies with Clause 3.8.3.8.(1)(b) and is capable of being locked from the inside, and released from the outside in case of emergency, and
  - ii) if it is an outward swinging door that is not self-closing, has a horizontal, D-shaped, visually contrasting door pull not less than 140 mm long located on the inside so that its midpoint is not less than 200 mm and not more than 300 mm from the hinged side of the door and not less than 900 mm and not more than 1 100 mm above the floor (see Note A-3.8.3.12.(1)(d)(vi)),
- e) have one lavatory conforming to Article 3.8.3.16.,
- f) have one water closet conforming to Article 3.8.3.14. and Clause 3.8.3.12.(1)(e),
- g) have a clear lateral transfer space adjacent to the water closet that conforms to Clause 3.8.3.12.(1)(b),
- h) have grab bars conforming to Clauses 3.8.3.12.(1)(f) and (g),
- i) have a coat hook conforming to Clause 3.8.3.12.(1)(h),
- j) have a toilet paper dispenser conforming to Clause 3.8.3.12.(1)(i),
- k) unless a counter space of not less than 200 mm by 400 mm is provided, have a shelf located not more than 1 200 mm above the floor with a useable surface of not less than 200 mm by 400 mm,
- l) be designed to permit a wheelchair to turn in an open space not less than 1 700 mm in diameter, and
- m) provide emergency lighting conforming to Article 3.2.7.3.

#### Note A-3.8.3.13.

Clear Floor Space in Universal Washrooms. Unobstructed areas in front of the lavatory, in front of the water closet and on one side of the water closet are necessary for maneuverability of a wheelchair. Wall-mounted fixtures may project into the required floor space, provided that such projections do not restrict the maneuvering space required for persons using wheelchairs. Although outward swinging doors are preferable for accessibility, inward swinging doors are also permitted.

#### 3.8.2.8.(15) Adult Change Table

In buildings containing Group A, Group B, Division 2 or Group E major occupancies where at least one of these major occupancies has an occupant load of more than 500, at least one universal washroom on the storey on which the main accessible entrance to the building is located shall incorporate an accessible change space conforming to Subsection 3.8.3. (See Note A-3.8.2.8.(15).)

#### 2) Adult Change Table Design Requirements

A universal washroom required to have an accessible change space as stipulated in Sentence 3.8.2.8.(15) shall

- a) be equipped with an adult-sized change table that is
  - i) designed to carry a minimum load of 1.3 kN,
  - ii) impervious to water, and
  - iii) designed to be easily cleaned,
- b) have a clear floor space to accommodate the adult-sized change table that is 810 mm wide by 1 830 mm long and does not overlap with the clear spaces required by Clauses (1)(e), (1)(j) and (c), and
- c) have a clear transfer space of 900 mm by 1 350 mm adjacent to the long side of the clear floor space for the adult-sized change table.

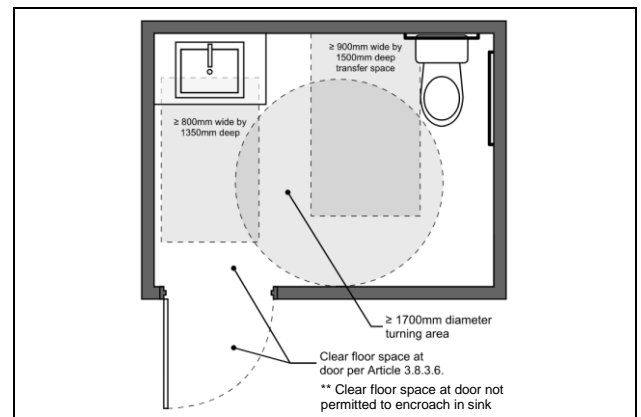

3.8.3.13.(1) Clear Floor Space

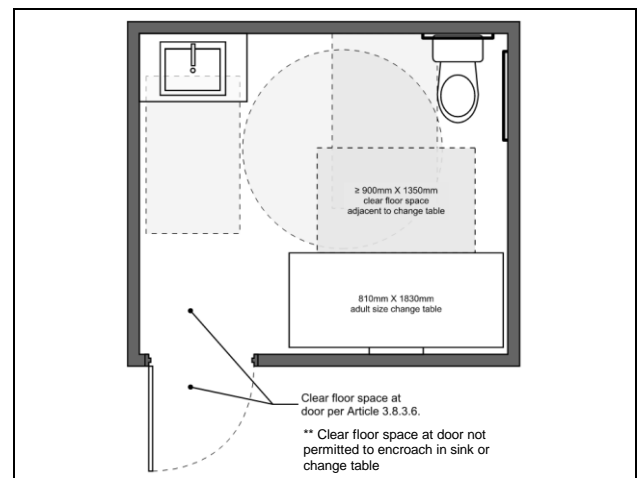

3.8.3.13.(2) Adult Change Table Clear Floor Space

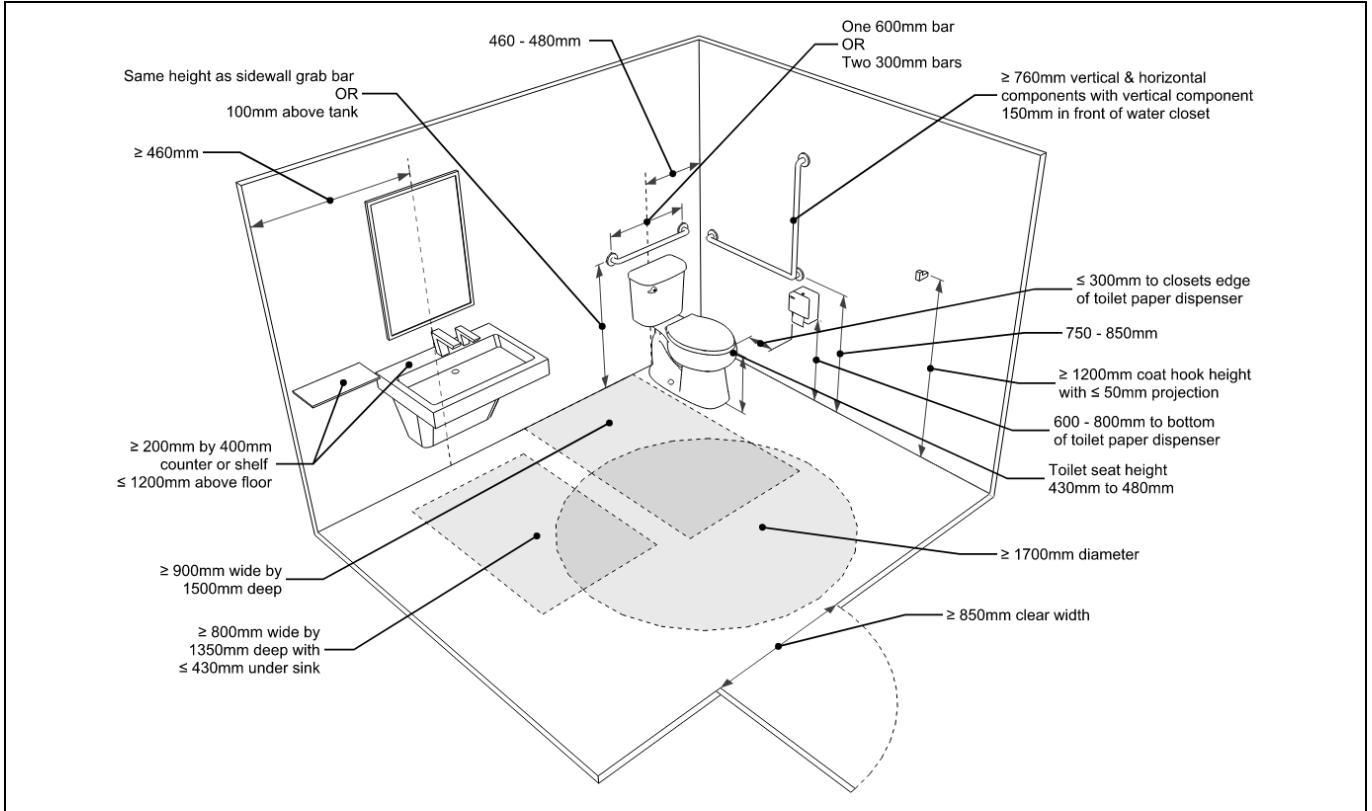

3.8.3.13.(1) Universal Washroom Requirements

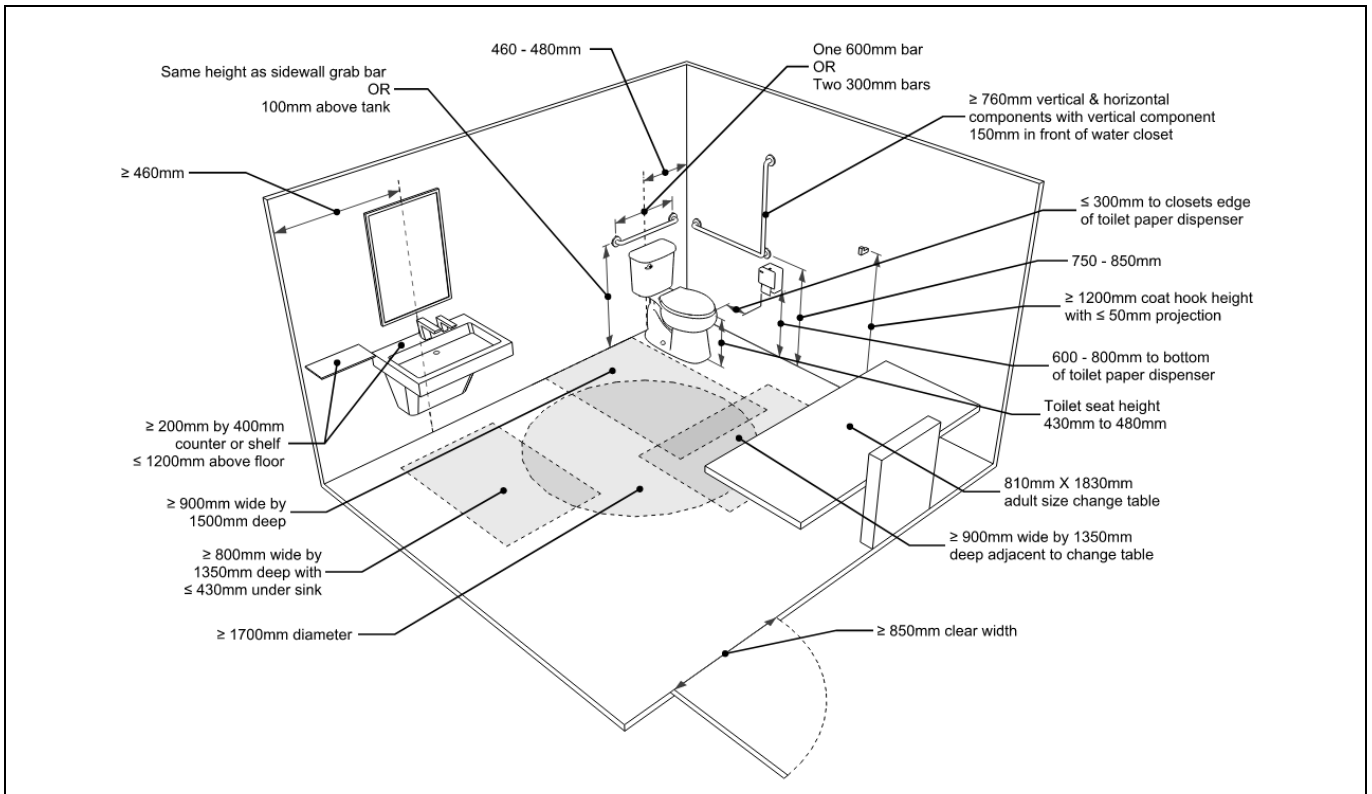

3.8.3.13.(1) & (2) Universal Washroom & Change Table Requirements

**(3.8.3.14) Water Closets****1) Water Closet Design Requirements**

A water closet for a person with physical disabilities shall

- a) be equipped with a seat located 430 mm to 480 mm above the floor,
- b) flush automatically or be equipped with a flushing control that
  - i) is located 500 mm to 900 mm above the floor,
  - ii) is located no more than 350 mm from the transfer side, and
  - iii) complies with Clause 3.8.3.8.(1)(b),
- c) be equipped with a seat lid or other back support, and
- d) where it has a tank, have a securely attached tank top.

(See Note A-3.8.3.14.(1).)

**Note A-3.8.3.14.(1)**

Water Closets. Wall- or floor-mounted water closets with recessed bases are preferable because they provide the least amount of obstruction.

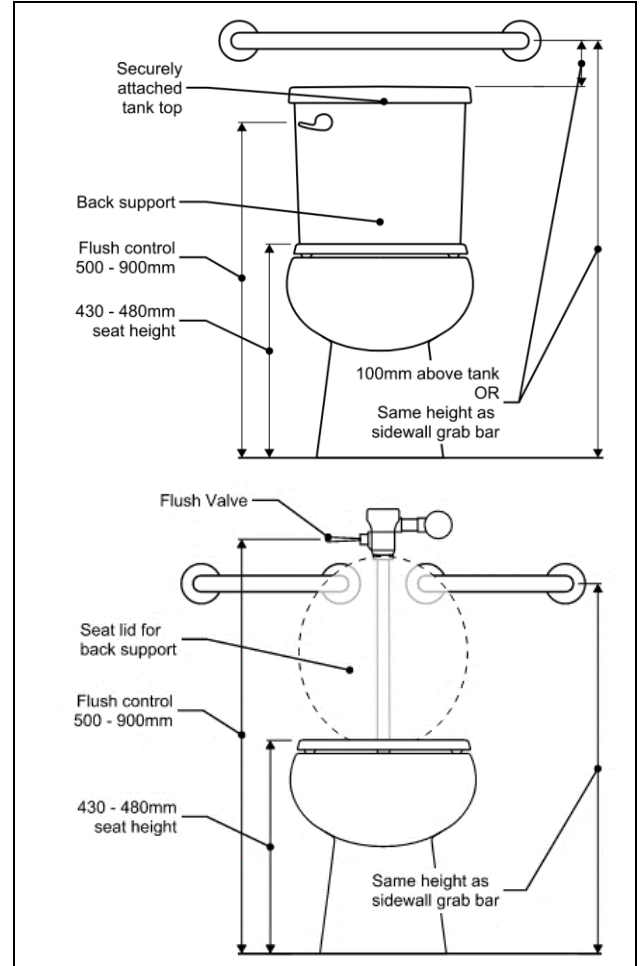

**3.8.3.14. Water Closet**



### (3.8.3.15) Water Closet Stalls & Urinals for Persons with Limited Mobility

#### 3.8.2.8.(7) Limited Mobility Water Closet Stalls

Where water-closet stalls are provided in an accessible washroom, at least one stall for persons with limited mobility conforming to Subsection 3.8.3. shall be provided for every 10 stalls.

#### 1) Water Closet Stall Design Requirements

Water-closet stalls for persons with limited mobility required by Sentence 3.8.2.8.(7) shall

- a) be at least 1 500 mm deep and 890 mm to 940 mm wide,
- b) be equipped with a door that
  - i) has a latch-operating mechanism conforming to Clause 3.8.3.8.(1)(b) that can be locked from the inside and released from the outside in the event of an emergency,
  - ii) provides a clear opening not less than 850 mm wide when it is open, measured in accordance with Sentence 3.8.3.6.(2),
  - iii) swings outward, unless the minimum dimensions required by Clause (a) do not overlap with the area of the door swing,
  - iv) is self-closing so that, when at rest, the door is ajar by not more than 50 mm beyond the jamb, and
  - v) has a horizontal, D-shaped, visually contrasting door pull on both sides of the door, near the latch side, located 900 mm to 1 100 mm above the finished floor,
- c) have one water closet conforming to Article 3.8.3.14. centred within the stall,
- d) have a horizontal grab bar conforming to Article 3.7.2.7. on each side of the water closet that
  - i) is located 750 mm to 850 mm above the floor,
  - ii) begins not more than 300 mm from the wall behind the water closet, and
  - iii) extends at least 450 mm in front of the toilet seat, and
- e) be equipped with a coat hook mounted not more than 1 200 mm above the floor on a side wall and projecting not more than 50 mm from the wall.

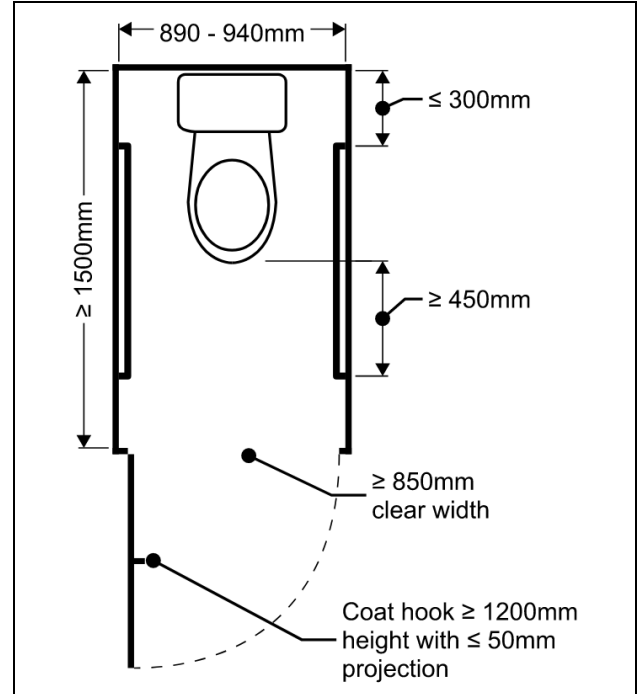

3.8.3.15.(1) Limited Mobility Stall Requirements - 2D

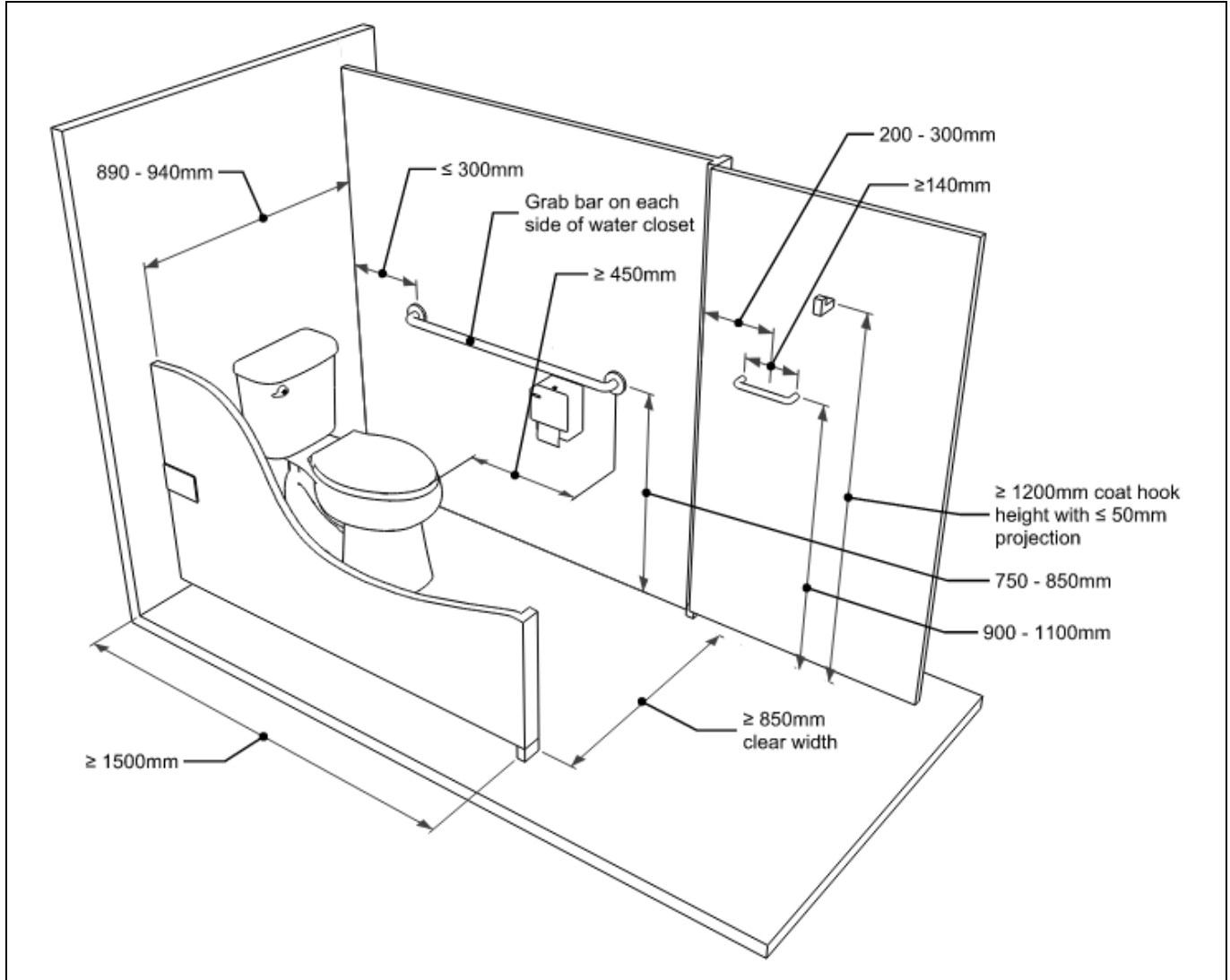

3.8.3.15.(1) Limited Mobility Stall Requirements - 3D

**3.8.2.8.(6) Limited Mobility Urinals**

Where urinals are provided in an accessible washroom, at least one urinal for persons with limited mobility conforming to Subsection 3.8.3. shall be provided for every 10 urinals.

**2) Urinal Design Requirements**

Urinals described in Sentence 3.8.2.8.(6) shall

- a) be wall-mounted, with the rim located not more than 430 mm above the floor,
- b) be adjacent to an accessible route,
- c) have a clear width of approach that is at least 800 mm wide by 1 350 mm long centred on the urinal and unobstructed by privacy screens,
- d) have no step in front of it,
- e) have a flush control that
  - i) is automatic, or
  - ii) complies with Clause 3.8.3.8.(1)(b) and is located 900 mm to 1 100 mm above the floor, and
- f) have a vertically mounted grab bar installed on each side that
  - i) complies with Article 3.7.2.7.,
  - ii) is not less than 600 mm long, with its centre line 1 000 mm above the floor, and
  - iii) is located not more than 380 mm from the centre line of the urinal.

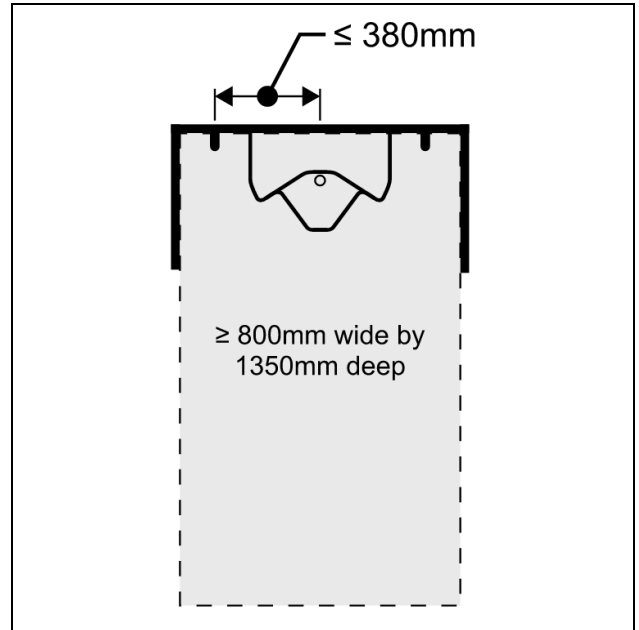

**3.8.3.15.(2) Limited Mobility Urinal Requirements - 2D**

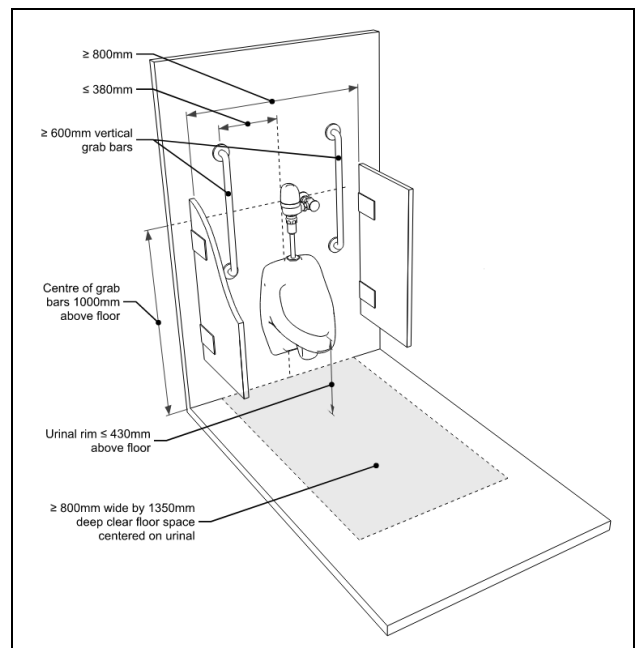

**3.8.3.15.(2) Limited Mobility Urinal Requirements - 3D**

### (3.8.3.16) Lavatories and Mirrors

#### 1) Lavatory Design Requirements

Lavatories required by Sentence 3.8.2.8.(8) shall

- a) be equipped with faucets complying with Sentence 3.7.2.3.(4),
- b) be located so that the distance between the centre line of the lavatory and any side wall is not less than 460 mm,
- c) have a clear floor space in front of the lavatory that is at least
  - i) 800 mm wide, centred on the lavatory, and
  - ii) 1 350 mm long, of which no more than 430 mm is beneath the lavatory,
- d) have a rim height not more than 865 mm above the floor,
- e) have a clearance beneath the lavatory not less than
  - i) 800 mm wide, centred on the lavatory,
  - ii) 735 mm high at the front edge,
  - iii) 685 mm high at a point 200 mm back from the front edge, and
  - iv) 230 mm high over the distance from a point 280 mm to a point 430 mm back from the front edge,
- f) have insulated water supply and drain pipes where these pipes are exposed (see Note A-3.8.3.16.(1)(f)),

#### Note A-3.8.3.16.(1)(f)

Pipe Protection. The pipes referred to in Clause 3.8.3.16.(1)(f) include both supply and waste pipes. The hazard can be prevented by insulating the pipes, by locating the pipes in enclosures, or avoided by limiting the temperature of the hot water to a maximum of 45°C..

- g) have a soap dispenser that
  - i) is automatic, or
  - ii) complies with Clause 3.8.3.8.(1)(b) and is located not more than 1 100 mm above the floor, within 500 mm from the front of the lavatory (see Note A-3.8.3.16.(1)(g)), and

#### Note A-3.8.3.16.(1)(g)

Soap Dispenser Location. The location of accessories, such as soap dispensers and faucets, serving accessible lavatories should be established while taking into consideration that their controls must be usable by and within the direct reach of a person in a seated position directly in front of the accessible lavatory.

- h) have a towel dispenser or other hand-drying equipment located close to the lavatory, with operating controls not more than 1 200 mm above the floor in an area that is accessible to persons using wheelchairs.

#### 2) Mirror Design Requirements

Mirrors required by Sentence 3.8.2.8.(9) shall be

- a) mounted with their bottom edge not more than 1 000 mm above the floor, or
- b) fixed in an inclined position so as to be usable by a person using a wheelchair.

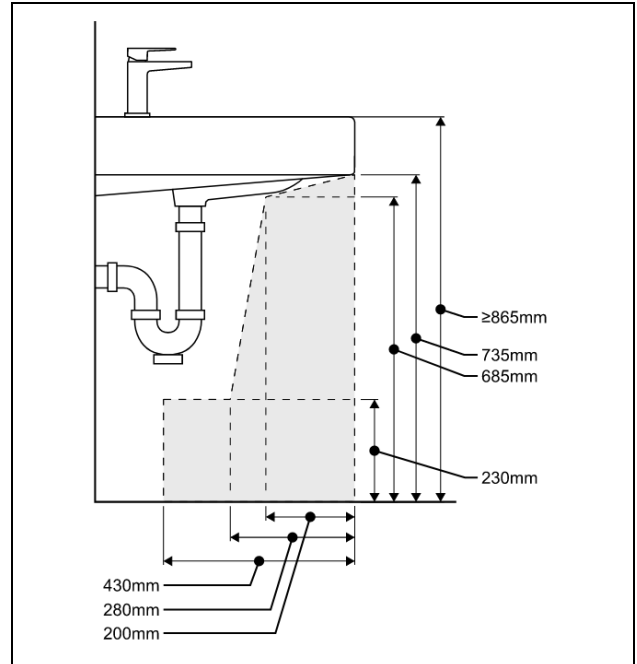

3.8.3.16. Clear Area Under Lavatory

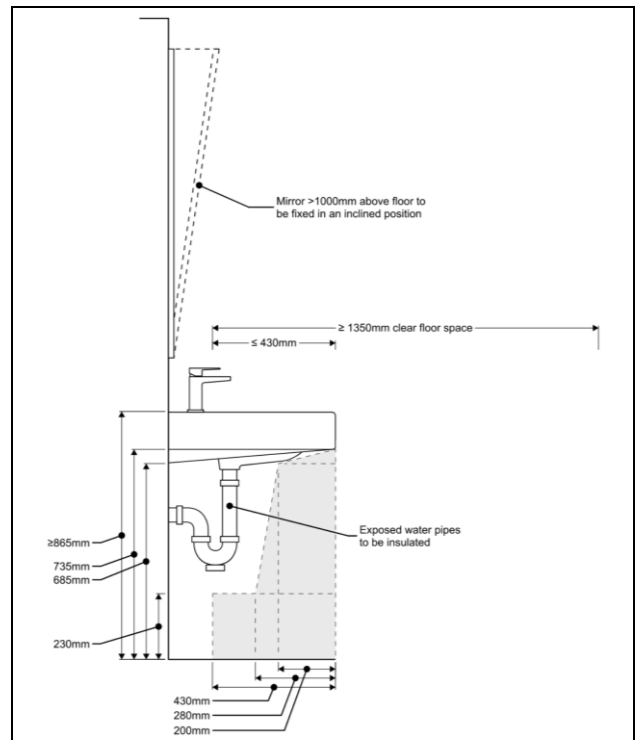

3.8.3.16. Lavatory & Mirror Requirements

**(3.8.3.17) Showers****3.8.2.8.(12) Shower**

Except within a suite of care occupancy or a suite of residential occupancy, where showers are provided in a building, at least one shower stall in each group of showers shall comply with Subsection 3.8.3.

**1) Shower Design Requirements:**

Showers required by Sentence 3.8.2.8.(12) shall

- a) be not less than 1 500 mm wide and 900 mm deep,
- b) have a clear floor space at the entrance to the shower that is not less than 900 mm deep and the same width as the shower, except that fixtures are permitted to project into that space provided they do not restrict access to the shower (see Note A-3.8.3.17.(1)(b)),

**Note A-3.8.3.17.(1)(b)**

Clear Space at Entrances to Showers. The clear space at the entrance to a shower may be encroached upon by fixtures such as a wall hung sink which does not interfere with the leg rests of the wheelchair. However, this sink could restrict movement for persons who need to make a lateral transfer if it were installed at the seat end of the shower.

- c) have no doors or curtains that obstruct the controls or the clear floor space at the entrance to the shower,

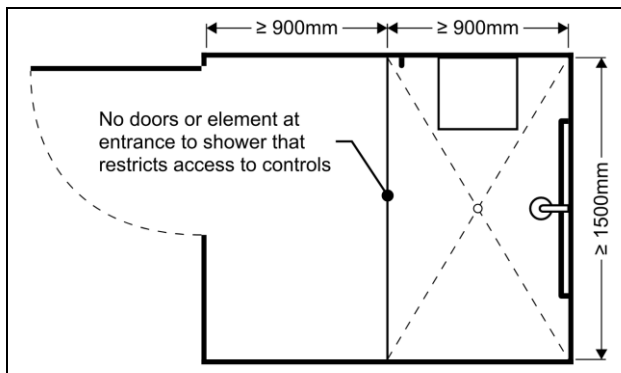

**3.8.3.17.(1) Shower Clear Floor Space**

- d) have a slip-resistant floor surface,
- e) have a threshold not more than 13 mm higher than the finished floor, and where it is higher than 6 mm, beveled to a slope no steeper than 1 in 2,

- f) have 2 grab bars
  - i) that conform to Sentence 3.7.2.7.(1),
  - ii) one of which is not less than 1 000 mm long and located vertically on the side wall 50 mm to 80 mm from the adjacent clear floor space, with its lower end 600 mm to 650 mm above the floor, and,
  - iii) one of which is L-shaped and located on the wall opposite the entrance to the shower, with a horizontal member not less than 1 000 mm long mounted 750 mm to 870 mm above the floor and a vertical member not less than 750 mm long mounted 400 mm to 500 mm from the side wall on which the other vertical grab bar is mounted, (see Note A-3.8.3.17.(1)(f)),

**Note A-3.8.3.17.(1)(f)**

Grab Bars. One L-shaped grab bar is required to be installed on the wall next to the seat. A grab bar behind the seat would prevent the user from leaning back against the wall, while one located on the wall opposite the seat cannot be reached from the seated position. The seat itself may be used in conjunction with the bar for transfer. If design flexibility is required, fold away grab bars can be used as an alternative.

- g) have a hinged seat that is not spring-loaded or a fixed seat with a smooth, slip-resistant surface and no rough edges, the seat being
  - i) not less than 450 mm wide and 400 mm deep,
  - ii) mounted on the same side wall as the vertical grab bar, at 460 mm to 480 mm above the floor,
  - iii) designed to carry a minimum load of 1.3 kN,
  - iv) impervious to water, and
  - v) designed to be easily cleaned,
- h) have a pressure-equalizing or thermostatic-mixing valve and other controls that
  - i) comply with Clause 3.8.3.8.(1)(b), and
  - ii) are mounted on the wall opposite the entrance to the shower at not more than 1 200 mm above the floor and within reach of the seat,
- i) have a hand-held shower head with not less than 1 800 mm of flexible hose located so that it
  - i) can be reached from a seated position,
  - ii) can be used in a fixed position at a height of 1 200 mm and 2 030 mm, and
  - iii) does not obstruct the use of the grab bars, and
- j) have recessed soap holders that can be reached from the seated position.

**3.8.2.8.(13) Universal Dressing & Shower Room**

At each location where a showering facility is provided for use by the general public or customers, or as part of a common-use area for employees, at least one universal dressing and shower room conforming to Subsection 3.8.3. shall be provided. (See Note A-3.8.2.8.(13).)

**2) Dressing & Shower Room Design Requirements:**

A universal dressing and shower room required by Sentence 3.8.2.8.(13) shall

- a) be located in an accessible path of travel,
- b) have a door capable of being locked from the inside and released from the outside in the event of an emergency,
- c) have a lavatory and a mirror conforming to Article 3.8.3.16.,
- d) have a shower conforming to Sentence (1),
- e) have a bench that is
  - i) at least 1 830 mm long by 760 mm wide and 480 mm to 520 mm high,
  - ii) designed to carry a minimum load of 1.3 kN,
  - iii) impervious to water, and
  - iv) designed to be easily cleaned,
- f) have a clear transfer space adjacent to the long side of the bench that is 900 mm wide and as long as the bench (see Note A-3.8.3.17.(2)(f)),

**Note A-3.8.3.17.(2)(f)**

Grab Bar at Bench. Where a bench in a universal dressing and shower room is located adjacent to a wall, it is recommended that a grab bar be installed to assist users in transferring to the bench.

- g) have a coat hook conforming to Clause 3.8.3.12.(1)(h), and
- h) provide emergency lighting conforming to Article 3.2.7.3.

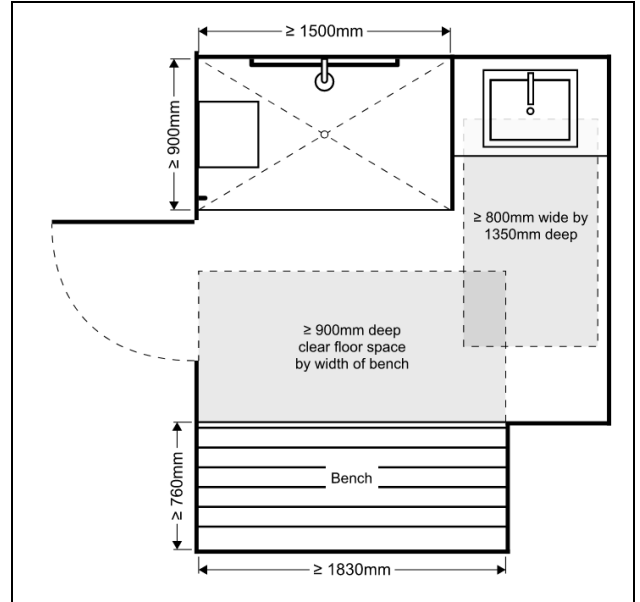
**3.8.3.17.(2) Shower Bench Clear Floor Space**

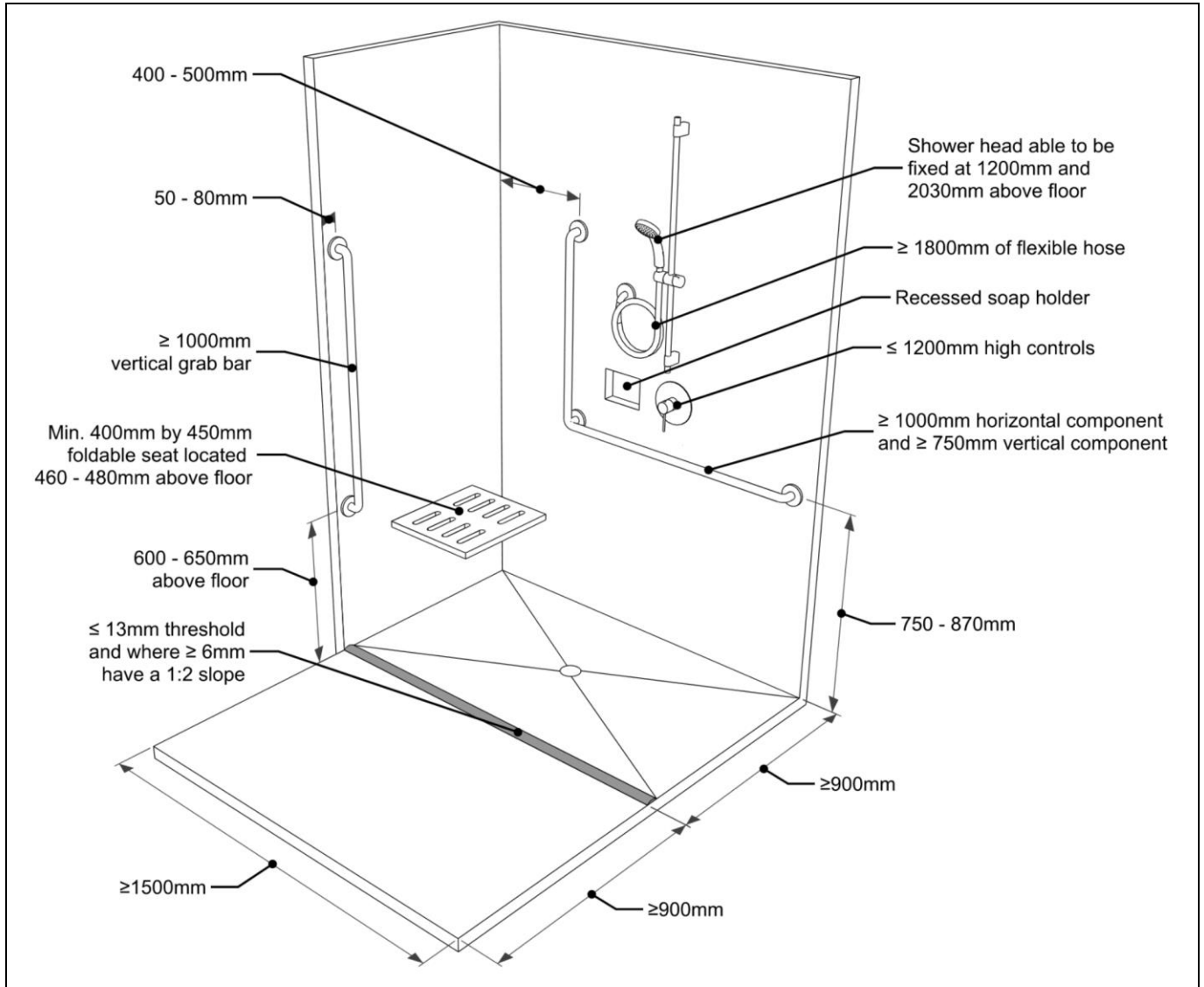

3.8.3.17.(1) Shower Requirements

**(3.8.3.18) Bathtubs****3.8.2.8.(14) Bathtub**

Where a bathtub is installed in a suite of residential occupancy required to be accessible, it shall comply with Subsection 3.8.3.

**1) Bathtub Design Requirements:**

A bathtub required by Sentence 3.8.2.8.(14) shall

- a) be located in a room with a clear floor space not less than 1 700 mm in diameter,
- b) be not less than 1 500 mm long,
- c) have a clear floor space at the entrance to the bathtub that is not less than 900 mm deep and at least the same length as the bathtub, except that fixtures are permitted to project into that space provided they do not restrict access to the shower,

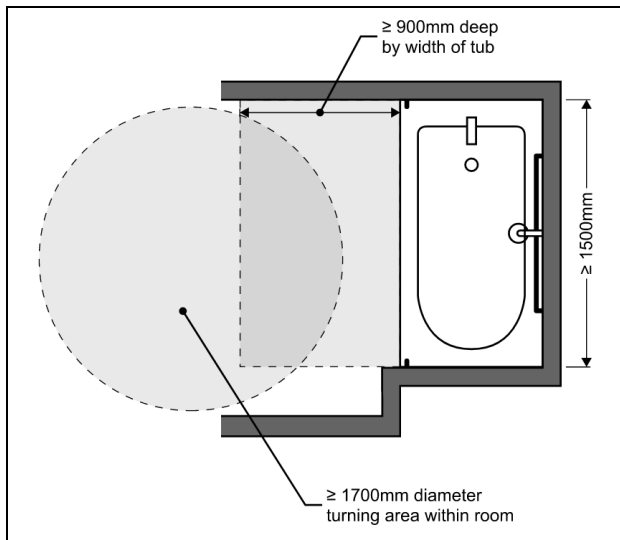
**3.8.3.18. Bathtub Clear Floor Space**

- d) be capable of being accessed along its full length with no tracks mounted on its rim,
- e) have a pressure-equalizing or thermostatic mixing valve and other controls that
  - i) conform to Clause 3.8.3.8.(1)(b), and
  - ii) are located on the centre line or between the centre line of the bathtub and the exterior edge of the bathtub rim, at a maximum height of 450 mm above the rim,

- f) have three grab bars
  - i) that conform to Sentence 3.7.2.7.(1),
  - ii) that are not less than 1 200 mm long,
  - iii) two of which are located vertically at each end of the bathtub, set 80 mm to 120 mm in from the outside edge of the bathtub, with their lower end 180 mm to 280 mm above the bathtub rim, and
  - iv) one of which is located horizontally along the length of the bathtub at 180 mm to 280 mm above the bathtub rim,
- g) have a slip-resistant bottom surface, and
- h) be equipped with a hand-held shower head with not less than 1 800 mm of flexible hose that can be used in a fixed position at a height of 1 200 mm and 2 030 mm.



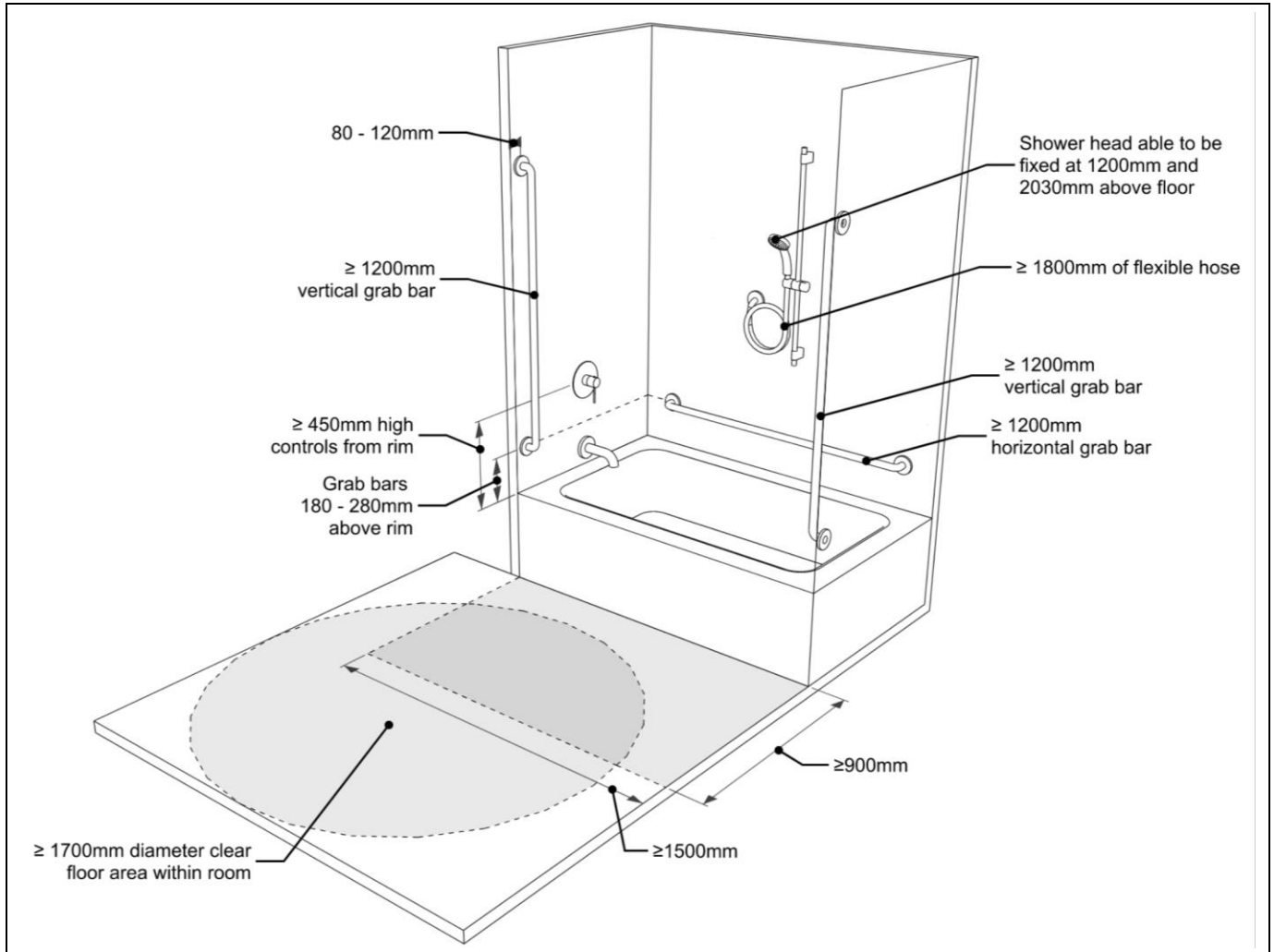

3.8.3.18. Bathtub Requirements

# 3 OTHER ACCESSIBLE AREAS



### (3.8.2.11) Application Requirements for Counters

#### 1) Required Accessible Counters:

Where a service counter is provided, at least one section of it shall comply with Subsection 3.8.3. (See Note A-3.8.2.11.(1).) (See also Note A-3.8.2.3.)

#### Note A-3.8.2.11.(1)

Counters with Work Surfaces. It is not intended that all counters be accessible, but that sufficient accessible counter space be available. Examples of counters that should be accessible include check-in counters and those in financial institutions and reception areas as well as any counter at which processing and signing of documents takes place. The provision is not intended to apply to work surfaces in industrial occupancies.

### (3.8.3.20) Counters

#### 1) Counter Design Requirements:

A section of a service counter required to be accessible in accordance with Sentence 3.8.2.11.(1) shall

- a) be not less than 800 mm long centred over a knee space conforming to Clause (c),
- b) have a surface not more than 865 mm above the floor, and
- c) where forward-facing interaction with a person or a device is required, have a knee space underneath it that is (see Note A-3.8.3.20.(1)(c))
  - i) not less than 800 mm wide,
  - ii) not less than 685 mm high, and
  - iii) not less than 485 mm deep.

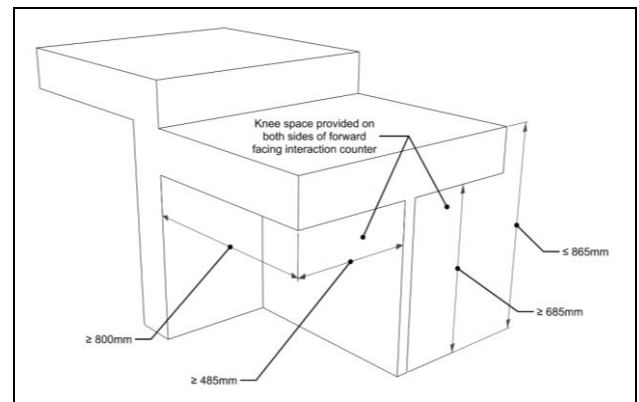

3.8.3.20. Service Counter

#### Note A-3.8.3.20.(1)(c)

Knee Space at Service Counters. Where forward-facing interaction with a person is required, the knee space requirement of Clause 3.8.3.20.(1)(c) applies to both sides of the service counter to ensure accessibility for both service providers and those receiving services..

### (3.8.2.12) Application Requirements for Telephone

#### 1) Required Accessible Telephone:

In each location where one or more public telephones are installed, at least one telephone shall comply with Subsection 3.8.3.

### (3.8.3.21) Telephones

#### 1) Telephone Design Requirements:

A telephone required to be accessible in accordance with Article 3.8.2.12. shall

- be adjacent to and centred on either the length or the width of a clear floor space not less than 1 350 mm by 800 mm,
- where a forward approach is provided, have a knee space underneath it conforming to Clause 3.8.3.20.(1)(c), and
- be located so that its receiver and operable parts are not more than 1 200 mm above the floor.

#### 2) Telephone Counter Design Requirements:

Where provided, shelves or counters for public telephones shall

- be level,
- be not less than 305 mm deep,
- have, for each telephone provided, a clear space not less than 250 mm wide having no obstruction within 250 mm above the surface, and
- have a section with a surface not more than 865 mm above the floor serving at least one telephone.

(See Note A-3.8.3.21.(2).)

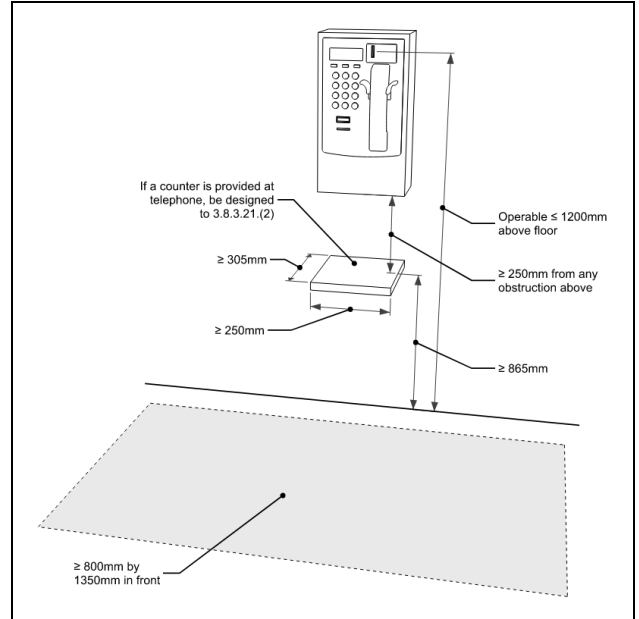

3.8.3.21. Telephone with Counter

#### Note A-3.8.3.21.(2)

Telephone Shelves or Counters. Built-in shelves or counters for public telephones must be designed to accommodate persons using text telephones (TT). These devices may also be referred to as teletypewriters (TTY) or telecommunication devices for the deaf (TDD). These devices require a level surface at least 305 mm deep by 250 mm wide with no obstruction above that space within 250 mm. If a wall-hung telephone or other obstruction extends to less than 250 mm from the shelf or counter, an equivalent clear space must be provided on either side of each telephone. At least one telephone should be equipped with a volume control on a receiver that generates a magnetic field compatible with the T-switch of a hearing aid. The lower portion of the shelf or counter is intended for persons using a wheelchair; therefore all parts of the operating mechanism of the telephone above this portion should be within reach of a person using a wheelchair.

### (3.8.2.3) Application Requirements for Wheelchair and Adaptable Spaces

**3) Wheelchair Spaces in Assembly Occupancies:**

In an assembly occupancy, the number of spaces designated for wheelchair use within rooms or areas with fixed seats shall conform to Table 3.8.2.3.

**4) Wheelchair Spaces in Waiting Room or Area with Fixed Seats:**

The number of spaces designated for wheelchair use within waiting rooms or areas with fixed seats shall conform to Table 3.8.2.3. (See Note A-3.8.2.3.(4).)

**Note A-3.8.2.3.(4)**

Waiting Areas with Fixed Seats. Many types of buildings have waiting areas, such as airports, hospitals, and government office buildings. Waiting areas should have a sufficient number of spaces designated for persons using wheelchairs so they can use the waiting area without blocking any means of egress.

The number of people using wheelchairs is typically much higher in treatment occupancies than in other types of occupancies. Designers should consider adding more designated wheelchair spaces in waiting areas than the numbers indicated in Table 3.8.2.3. in occupancies where a higher number of persons using wheelchairs is expected due to the types of services provided.

**Table 3.8.2.3.  
Designated Wheelchair Spaces Forming  
Part of Sentences 3.8.2.3.(3) and (4)**

# of Fixed Seats in Seating Area	# of Wheelchair Spaces Required for Wheelchairs
2 – 99	2
100 – 499	3 plus 1 for each additional increment of 70 seats in excess of 100
500 – 1999	9 plus 1 for each additional increment of 80 seats in excess of 500
2000 – 7999	28 plus 1 for each additional increment of 95 seats in excess of 2000
Over 7999	91 plus 1 for each additional increment of 100 seats in excess of 8000

**5) Seating with Additional Features in Assembly Occupancies:**

Except as provided in Sentence (6), in an assembly occupancy with more than 25 fixed seats, each row of seats served by two aisles shall have one adaptable seat conforming to Subsection 3.8.3. located adjacent to one of the aisles.

**6) Location of Seating with Additional Features:**

At least 5% of the adaptable seats required by Sentence (5) but no more than 20 adaptable seats shall adjoin an accessible path of travel.

### (3.8.3.22) Spaces in Seating Areas

#### 1) Assembly Seating Space Design Requirements:

Spaces designated for wheelchair use in assembly occupancies as required by Sentence 3.8.2.3.(3) shall conform to the following:

- at least one designated space shall be clear and level for each increment of 200 seats and the remaining designated spaces shall be level and have removable seats,
- they shall be not less than 900 mm wide and 1 700 mm long to permit a wheelchair to enter from a side approach and 1 350 mm long where the wheelchair enters from the front or rear of the space,
- they shall be arranged so that
  - at least two designated spaces are located side by side, and
  - at least one fixed seat is located beside each designated space,
- they shall be located adjoining an accessible path of travel without infringing on egress from any row of seating or any aisle requirements, and
- they shall be situated, as part of the designated seating plan, to provide a choice of viewing location and a clear view of the event taking place.

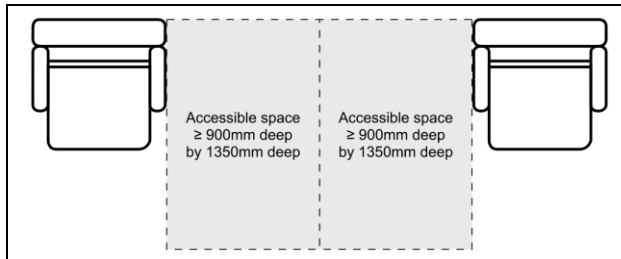

3.8.3.22.(1) Assembly Accessible Space Location

#### 2) Wheelchair Spaces Waiting Room Design Requirements:

Spaces designated for wheelchair use in waiting rooms or areas as required by Sentence 3.8.2.3.(4) shall

- be clear and level, and
- comply with Clauses (1)(b) and (d).

#### 3) Seating with Additional Features:

Adaptable seats required by Sentence 3.8.2.3.(5) shall

- be located adjoining an aisle without infringing on egress from any row of seating or any aisle requirements,
- be equipped with a movable or removable armrest on the side of the seat adjoining the aisle, and
- be situated, as part of the designated seating plan, to provide a choice of viewing location and a clear view of the event taking place.

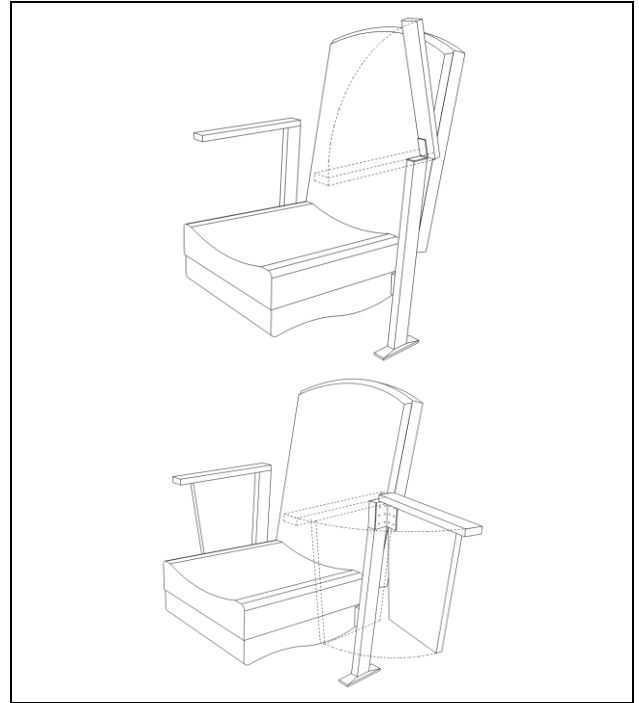

3.8.3.22.(3) Adaptable Seat Design Examples

#### 4) Mobility Aid Storage Space Design Requirements:

Storage spaces for mobility aids shall be provided in a location

- that is on the same level as and in proximity to the adaptable seats required by Sentence 3.8.2.3.(5),
- that is within the room side of the fire separation required by Article 3.3.2.2., and
- where they will not infringe on egress.

(See Note A-3.8.3.22.(4))

#### Note A-3.8.3.22.(4)

Storage Spaces for Mobility Aids. The intent of Sentence 3.8.3.22.(4) is that a sufficient number of storage spaces for mobility aids other than wheelchairs and scooters (e.g., walkers) be located such that they can be accessed without leaving the seating area. These storage spaces should preferably be visible from the adaptable seats. The storage spaces may be located adjacent to an aisle but must not reduce the required egress width of the aisle or obstruct egress from the rows of seats.

### (3.8.2.13) Application Requirements for Sleeping Rooms and Bed Spaces

- 1) **Required Accessible Sleeping Rooms:**  
At least one for every 20 or part thereof of sleeping rooms or bed spaces shall conform to Subsection 3.8.3. where provided in
  - a) hotels and motels (see also Clause 3.2.4.19.(1)(g) and Sentences 3.2.4.20.(7) and (8)), and
  - b) not including apartments and condominiums and the buildings described in 3.8.2.1.(1)(a), other buildings or parts of buildings used for residential major occupancies (see also Sentence 3.2.4.20.(17)).

### (3.8.3.23) Sleeping Rooms and Bed Spaces

- 1) **Sleeping Room Design Requirements:**  
Sleeping rooms and bed spaces required by Sentence 3.8.2.13.(1) to be accessible shall have
  - a) a clear floor space that permits a turning area of not less than 1 700 mm in diameter, or not less than 1 700 mm by 1 500 mm, that could be adjacent a bed,
  - b) a pathway clearance of not less than 1 000 mm wide, that could be unobstructed by a bed, to allow functional use of the bedroom,
  - c) at least one closet that provides
    - f) a clear opening width of not less than 900 mm,
    - iii) a clear floor space, that need not be separate from the turning areas required in Clause (a), of not less than 1 700 mm by 1 500 mm on at least one side of the closet (see Note A-3.8.5.6.(1))
    - iv) clothes hanger rods capable of being lowered to a height of not more than 1 200 mm, and
    - v) at least one shelf capable of being lowered to a height of not more than 1 200 mm,
  - d) when a balcony is provided, an accessible path of travel to an accessible balcony conforming to Sentence 3.3.1.7.(4),
  - e) except for dedicated electrical outlets for equipment and appliances, where controls, switches and outlets are intended for frequent operation, they shall conform to Subsection 3.8.3., and
  - f) a bathroom, where provided as part of the sleeping room or bed space, or access to a bathroom, where not provided as part of the sleeping room or bed space
    - i) conforming to Clauses 3.8.3.12.(1)(a), (b), (e), (f), (g), (h) and (i) with a water closet conforming to Article 3.8.3.14.,
    - ii) provided with a lavatory and mirror conforming to Article 3.8.3.16., and
    - iii) provided with a shower conforming to Article 3.8.3.17. or a bathtub conforming to Article 3.8.3.18., only to the extent of providing the same type of facilities provided in sleeping rooms and bed spaces where access is not required.

### (3.2.4.19) Visible Signals

- 1) **Visible Signal Device in Sleeping Rooms:**  
Where a fire alarm system is installed, visible signal devices shall be provided in addition to alarm signal devices
  - g) in not less than 10% of the suites of residential occupancy in a hotel or motel (see Note A-3.2.4.19.(1)(g))

#### Note A-3.2.4.19.(1)(g)

Visible Alarm Signals in Hotels and Motels. Visible signal devices should be installed in a combination of regular suites and designated accessible suites in hotels and motels so that people who are deaf or hard of hearing can safely occupy either type of suite.

Visible signal devices are not required to be installed in all the rooms of the suite. The signal should be visible from any room in the suite, which can be accomplished by installing glazing panels between the rooms or additional visible signal devices.

In addition, CAN/ULC-S524, "Standard for Installation of Fire Alarm Systems," requires that high-intensity strobes be used in sleeping rooms.

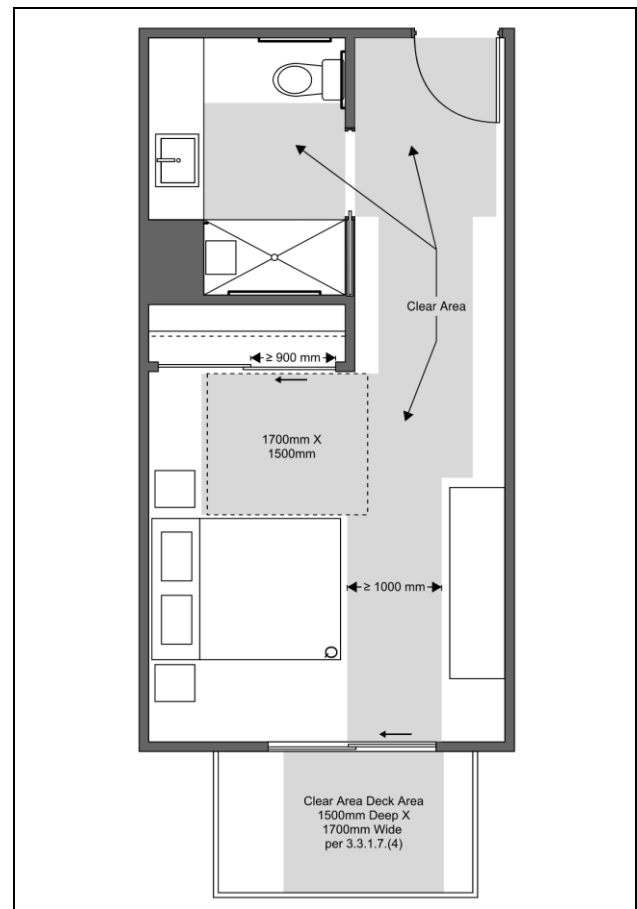

3.8.3.23. Sleeping Room

# 4 ACCESSIBLE CONTROLS, SIGNS & DEVICES





**(3.8.2.6) Application Requirements for Controls and Outlets**

**1) Required Accessible Controls**

Except as provided in Sentence 3.5.2.1.(3), controls for the operation of building services or safety devices, including electrical switches, thermostats, faucets, door and window hardware and intercom systems and switches, that are intended to be operated generally by the occupant shall comply with Subsection 3.8.3. (See Note A-3.8.2.6.(1).)

**Note A-3.8.2.6.(1)**  
Application to Security Access Systems. Sentence 3.8.2.6.(1) is not intended to reduce the functionality of security devices that limit access to secure areas and are addressed by other Sections of this Code.

**2) General Outlet Use**

Electrical outlets that are intended for general occupant use shall be located in conformance with Subsection 3.8.3. (See Note A-3.8.2.6.(2).)

**Note A-3.8.2.6.(2)**  
Electrical Outlets. Electrical outlets intended for general occupant use shall be located so that their height above the finished floor is not a barrier to use. Outlets that are dedicated for specific equipment or functions and not intended to be readily available to occupants need not conform to the location requirements.

Refer to Article 3.2.7.1. for illumination requirements at controls.

**(3.8.3.8) Controls and Outlets**

**1) Control Installation:**

Controls described in this Section shall

- a) where located in a storey where an accessible path of travel is required and unless otherwise stated,
  - i) be in or adjacent to the accessible path of travel,
  - ii) be mounted 400 mm to 1 200 mm above the floor, and
  - iii) be adjacent to and centred on either the length or the width of a clear floor space of 1 350 mm by 800 mm,
- b) be operable
  - i) with one hand in a closed fist position, without requiring tight grasping, pinching with fingers, or twisting of the wrist, and
  - ii) unless otherwise stated, with a force not more than 22 N, and
- c) where controls provide a feedback signal to the user, it shall be both audible and visible (see Note A-3.8.3.8.(1)(c)).

**Note A-3.8.3.8.(1)(c)**  
Controls with Feedback Signals. Security access systems are a typical example of systems that have controls that provide feedback signals, such as illumination and an audible cue, which should be accessible to all users.

**2) Electrical Outlet Installation:**

Electrical outlets described in this Section shall be located in conformance with Subclause (1)(a)(ii). (See Note A-3.8.2.6.(2).)

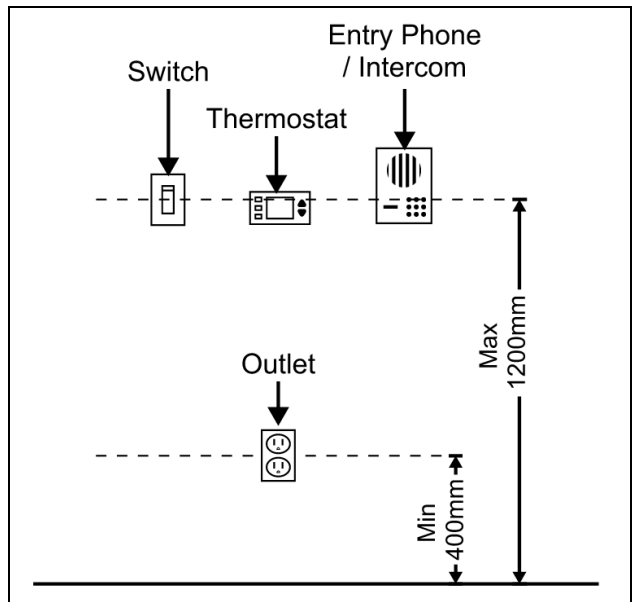

**3.8.3.8. Control and Outlet Heights**

### (3.8.2.10) Application Requirements for Signs and Indicators

- 1) **Required Accessible Signage:**  
Unless the degree of access provided is such as to make these signs unnecessary, signs providing visual information in accordance with Subsection 3.8.3. shall be installed to indicate the location of
  - a) accessible entrances,
  - b) alternative access routes,
  - c) accessible spaces in seating areas,
  - d) accessible refreshment facilities,
  - e) accessible checkout lanes,
  - f) accessible public telephones,
  - g) accessible washrooms,
  - h) accessible showers,
  - i) accessible passenger-elevating devices,
  - j) accessible parking spaces,
  - k) accessible passenger loading zones, and
  - l) assistive listening systems or adaptive technologies.
- 2) **Signage to Accessible Washroom Facilities:**  
Where a washroom is not designed to accommodate persons with physical disabilities in a storey to which an accessible path of travel is required, signs providing visual and tactile information in accordance with Subsection 3.8.3. shall be installed to indicate the location of accessible washrooms.
- 3) **Signage at Doors:**  
Except for doors that serve service spaces or are located within a suite, signs installed at or near doors shall provide the same information in both visual and tactile forms in accordance with Subsection 3.8.3.
- 4) **Directional Signage:**  
Directional signs shall provide visual information in accordance with Subsection 3.8.3. (See Note A-3.8.2.10.(4).)

#### Note A-3.8.2.10.(4)

Directional Signage. This Code requires that directional signs be provided in a number of situations. Although they are only required to provide visual information, tactile directional signs should also be provided where practicable.

In some buildings, it may be necessary to supplement signs that provide visual and tactile information with visual displays, such as information displays and electronic interactive displays (e.g., wayfinding, exhibits and self-serve points-of-sale). Visual displays are common in motion picture theatres, law courts, exhibition halls, passenger stations/depots, museums, conference facilities, shops, stores and markets.

Wherever practicable, visual displays should be designed so that they are accessible to all people. In order to be accessible to people with low vision, visually displayed information should also be audibly communicated, either electronically or orally. Where touch screens are installed, an alternative means of accessing the information should be provided, for example by providing tactile buttons on an interactive display or by ensuring an attendant is always available to assist customers or visitors. Visual displays should also be accessible to people who use mobility devices. The degree of operability should accommodate people using a wide range of mobility devices (e.g., wheelchairs, scooters, walkers, canes) and people with a wide range of arm and hand mobility. Approach side, mounting height above the finished floor, amount of knee space, types of controls and the ability to reach them are particularly important considerations.

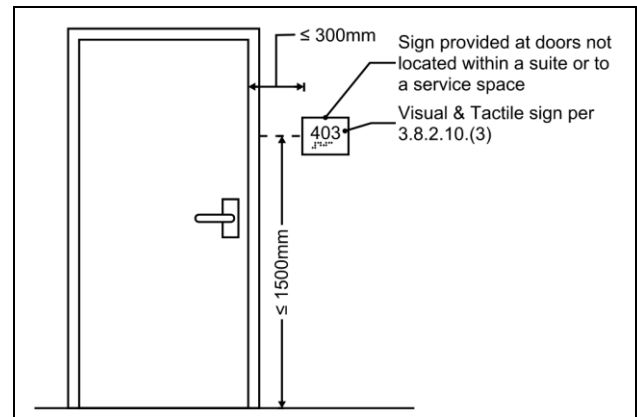

3.8.2.10.(3) Signage Provided at Doors  
(E.g. Suite Entry Door)

**(3.8.3.9) Accessible Signs**

- 1) **Visual Sign Design Requirements:**  
 Visual information signs required by Subsections 3.4.5. <Exit and Tactile Exit Signs> and 3.4.6. <Maglock, Crossover, Floor Numbering, and Stair Identification Signs> and Article 3.8.2.10. <Accessible Signs> shall comply with Clauses 4.5.1, 4.5.2, 4.5.3 and 4.5.4 of CSA B651, "Accessible design for the built environment."

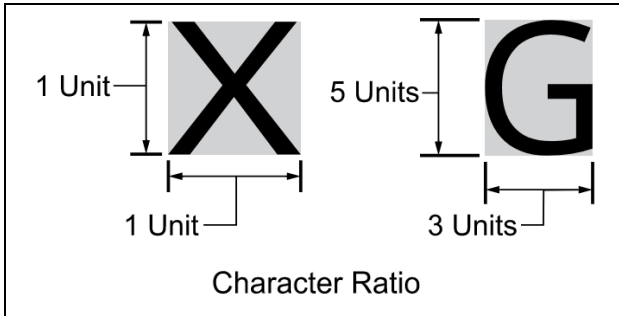

**3.8.3.9. Character Ratio**

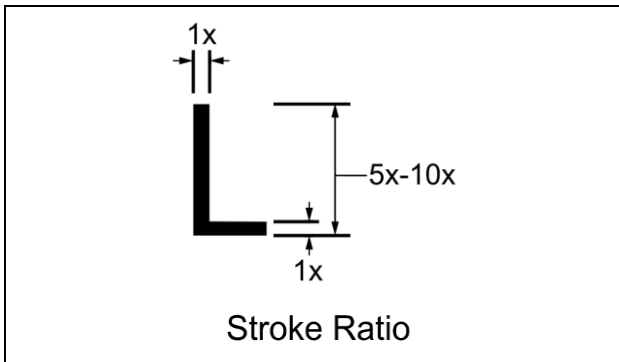

**3.8.3.9. Stroke Ratio**

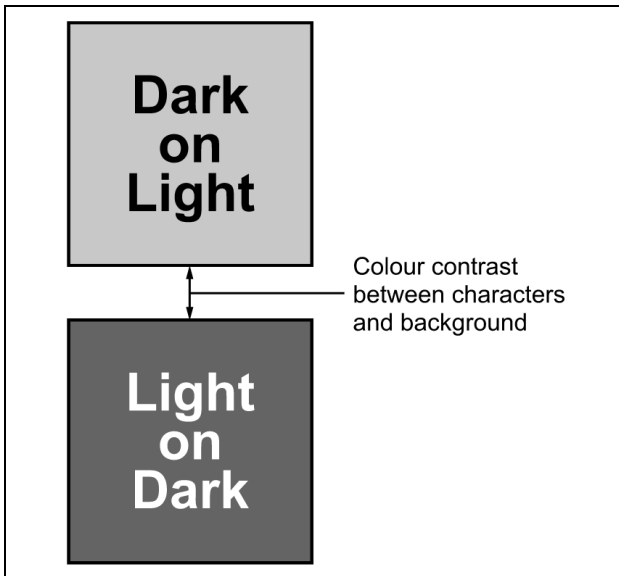

**3.8.3.9. Sign Contrasting Colours**

**CSA B651-18 Clauses 4.5.1 to 4.5.4**

**4.5.1. Location**

Where signage, including electronic, displays, is provided it shall be

- a) Consistently located; and
- b) Positioned to avoid shadow areas and glare.

**4.5.2. Configuration of signs**

Where signage, including electronic displays, is provided, it shall

- a) have a glare-free surface;
- b) be of uniform design;
- c) where used to give the same type of information within the same facility, be consistently shaped, coloured and positioned; and
- d) be colour-contrasted with its background.

**4.5.3. Characters**

On signs letters and numerals shall

- a) be sans serif;
- b) have Arabic numerals;
- c) have a width-to-height ratio between 3:5 and 1:1
- d) have a stroke-width-to-height ratio between 1:5 and 1:10;
- e) be colour-contrasted by at least 70% with background;
- f) have the character height sized relative to the intended viewing distance; and
- g) use an uppercase "X" for character measurements.

**Table 4**  
**Character height relative to viewing distance**  
 (See Clause 4.5.3.)

Minimum character height, mm	Maximum viewing distance, mm
25	750
50	1500
75	2250
100	3000
150	4500
200	6000
250	7500
300	9000

**4.5.4. Pictograms and symbols**

Pictograms and symbols shall be colour-contrasted by at least 70% with their background



**2) Tactile Sign Design Requirements:**

Tactile information signs required by Subsections 3.4.5. and 3.4.6. and Article 3.8.2.10. shall

- have Braille and tactile characters in accordance with Clauses 4.5.6.2 and 4.5.6.3 of CSA B651, "Accessible design for the built environment,"
- be installed on the wall closest to the latch side of the door or on the nearest wall on the right side of the door, where there is no wall at the latch side, and
- be centred 1 500 mm above the finished floor with the edge of the sign located not more than 300 mm from the door.

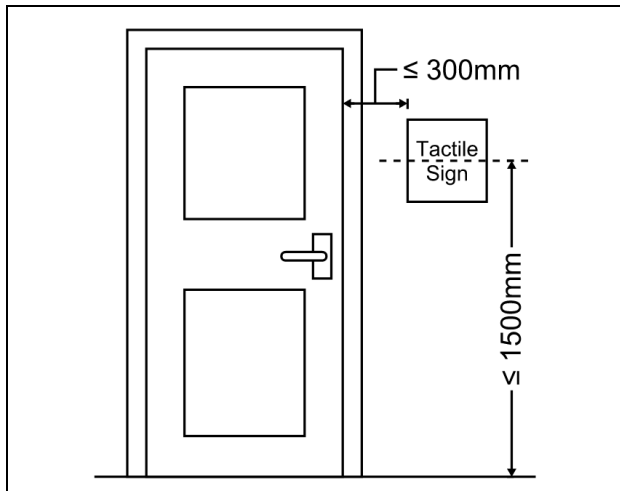

**3.8.3.9. Tactile Sign Installation Location**

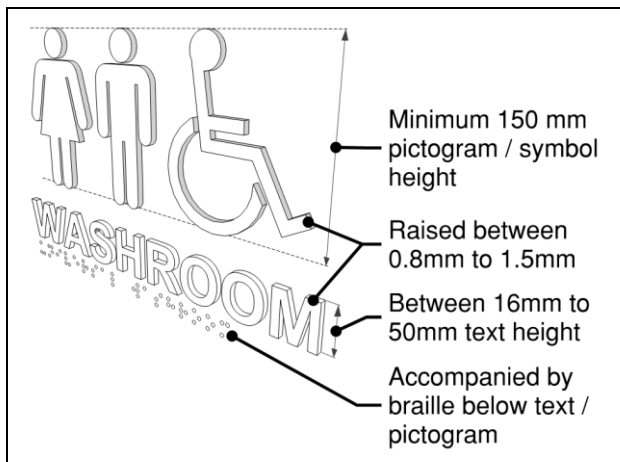

**3.8.3.9. Tactile Sign Design**

**CSA B651-18 Clauses 4.5.6.2 & 4.5.6.3****4.5.6.2. Tactile characters**

On tactile signs, letters and numerals shall be signage, including electronic, displays, is provided it shall be

- raised between 0.8 and 1.5 mm above the surface;
- sans serif;
- 16 to 50 mm in height;
- accompanied by braille near the bottom edge of the sign; and
- colour-contrasted with their background by at least 70%

**4.5.6.3. Pictograms and symbols**

On tactile signs, pictograms and symbols shall be

- raised between 0.8 and 1.5 mm above the surface (see Figure 11);
- at least 150 mm in height;
- accompanied by the equivalent description in uncontracted braille, placed directly below the pictogram or symbol; and
- colour-contrasted with their background by at least 70%.

**3) Symbol of Access on Accessible Signs:**

Signs required by Article 3.8.2.10. shall incorporate the International Symbol of Access, Modified International Symbol of Access, or the International Symbol of Access for Hearing Loss and appropriate graphical or textual information that clearly indicates the type of facilities available. (See Note A-3.8.3.9.(3).)

**Note A-3.8.3.9.(3)**

Accessibility Signs. The International Symbol of Access shown in Figure A-3.8.3.9.(3)-A indicates to persons with physical disabilities that they will have reasonable freedom of movement within a building so signed. The symbol is usually white on a blue background; where these colours do not stand out, the sign can be set on a white background. An arrow can be added to indicate direction or the location of an accessible space or facility.

**(3.4.5.2.) Exit Signs with Tactile Information**

- 1) An exit sign displaying the word “EXIT” in tactile form that complies with Subsection 3.8.3. shall be mounted on the approach side of exit doors described in Sentence 3.4.5.1.(1), in the direction of travel to the exit.

**(3.4.6.19.) Floor Numbering at Exit Stairs**

- 1) Arabic numerals indicating the assigned floor number in both visual and tactile forms in accordance with Subsection 3.8.3. shall be mounted permanently on the wall on the stair side and on the floor side at the latch side of doors to exit stair shafts.

**(3.4.6.19.) Identification of Stair Shafts**

- 2) Upper case letters indicating the designation assigned to each exit stair shaft in both visual and tactile forms in accordance with Subsection 3.8.3. shall be mounted permanently on the wall on the stair side and on the floor side at the latch side of doors to exit stair shafts.

**(3.4.6.18.) Crossover Signs**

- 3) Doors referred to in Sentence (1) shall be identified by visual and tactile information signs complying with Subsection 3.8.3. mounted on the stairway side to indicate that they are openable from that side
- 4) Locked doors intended to prevent entry into a floor area from an exit stair shall
  - a) be identified by visual and tactile information signs complying with Subsection 3.8.3. mounted on the stairway side to indicate the location of the nearest unlocked door in each direction of travel

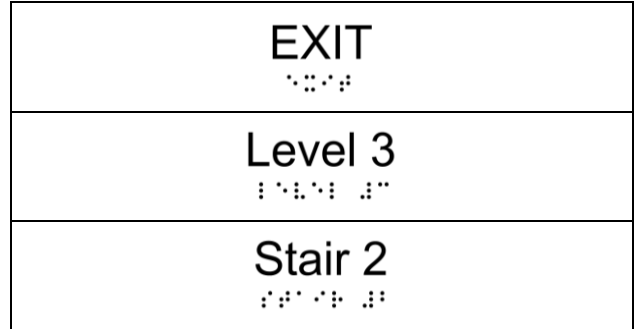

**3.4.5.2. & 3.4.6.19. Examples of Exit, Stair & Floor Sign Info**

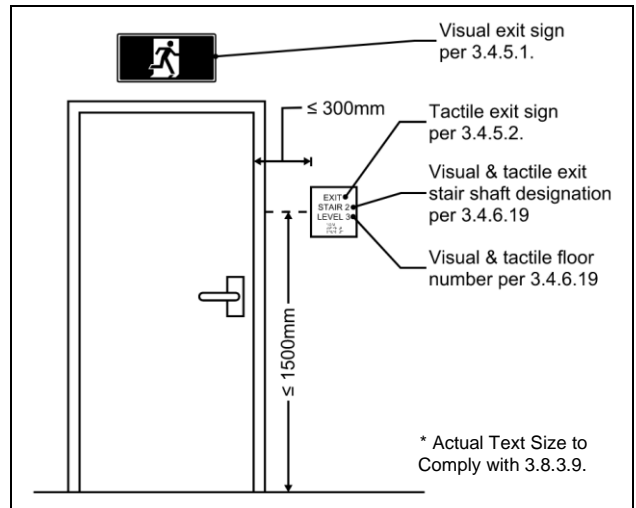

**3.4.5.2. & 3.4.6.19. Signage Required at Exit Stair Door**

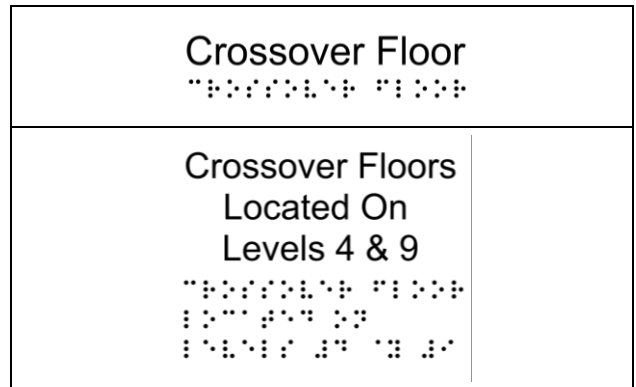

**3.4.6.18. Examples of Crossover Sign Info**

**(3.4.6.16.) Maglock Signs**

- 5) Electromagnetic locks that do not incorporate latches, pins or other similar devices to keep the door in the closed position are permitted to be installed on doors, other than those leading directly from a high-hazard industrial occupancy, provided
  - g) a visual information sign complying with Subsection 3.8.3. is permanently mounted on the door to indicate that the locking device will release within 15 s of applying pressure to the door-opening hardware
  - h) a tactile information sign complying with Subsection 3.8.3. is permanently mounted near the door to indicate that the locking device will release within 15 s of applying pressure to the door-opening hardware,
- 6) Electromagnetic locks that do not incorporate latches, pins or other similar devices to keep the door in the closed position are permitted to be installed on doors in Group B, Division 2 and Division 3 occupancies, provide
  - d) a visual information sign complying with Subsection 3.8.3. that displays the words “Emergency exit unlocked by fire alarm” is permanently mounted on the door,
  - e) a tactile information sign complying with Subsection 3.8.3. that displays the words “Emergency exit unlocked by fire alarm” is permanently mounted near the door,

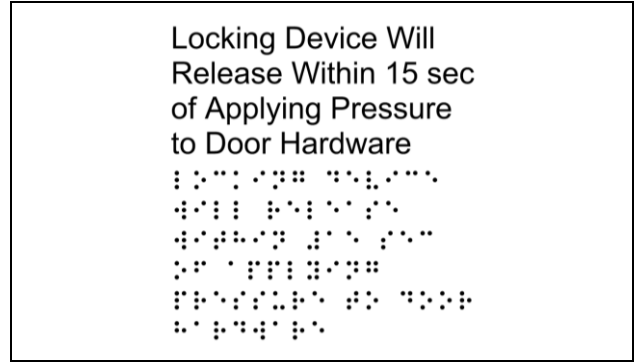

**3.4.6.16.(5) Example of Tactile Maglock Sign**

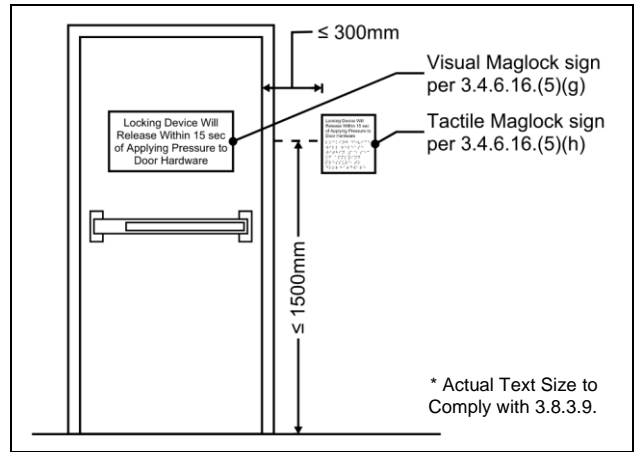

**3.4.6.16. Signage Required at Maglock Door**

**(3.5.4.2.) Floor Numbering at Elevators**

- 1) Arabic numerals indicating the assigned floor number shall be mounted permanently on both jambs of passenger elevator hoistway entrances in conformance with Appendix E of ASME A17.1/CSA B44, “Safety Code for Elevators and Escalators.”

**(3.2.7.1.) Illumination on Signs**

- 7) Except for internally illuminated signs, the minimum level of illumination at signs displaying visual information required by Clauses 3.4.6.10.(5)(b) *<Horizontal Exit Sign>* and 3.4.6.16.(5)(g) *<Maglock 15s Delay Sign>*, Subclause 3.4.6.16.(5)(l)(ii) *<Maglock at Crossover Re-Entry Sign>*, Clause 3.4.6.16.(6)(d) *<Group B Maglock Sign>*, Sentence 3.4.6.18.(3) *<Crossover Floor Sign>*, Clause 3.4.6.18.(4)(a) *<Closest Crossover Floor Sign>* and Articles 3.4.6.19. *<Floor Numbering>* and 3.8.2.10. *<Accessible Signs>* shall be not less than 200 lx.

**(3.8.2.9) Application Requirements for Assistive Listening Systems**

- 1) **Required System at Spaces:**  
In a building of assembly occupancy, all classrooms, auditoria, meeting rooms and theatres with an area of more than 100 m<sup>2</sup>, including courtrooms of any size, shall be equipped with an assistive listening system complying with Subsection 3.8.3.
- 2) **Required System at Service Counter:**  
In each location where information, goods or services are provided to the public at service counters in buildings of assembly occupancy, at least one of the service counters shall be equipped with
  - a) an assistive listening system or adaptive technology conforming to Subsection 3.8.3., and
  - b) an amplification system, where there is a barrier to communication, such as a glass screen.

(See Note A-3.8.2.9.(2).)

**Note A-3.8.2.9.(2)**  
Assistive Listening Systems and Adaptive Technologies. The intent of Sentence 3.8.2.9.(2) is to require that at least one counter with an assistive listening system or adaptive technology be provided at each group of service counters providing the same exchange of information, goods or services. For example, in a stadium with ticket counters at multiple building entrances, at least one ticket counter at each entrance should be equipped with an assistive listening system or adaptive technology.

**(3.8.3.19) Assistive Listening Systems**

- 1) **Coverage of System:**  
Assistive listening systems required by Sentence 3.8.2.9.(1) shall encompass the entire seating area.
- 2) **Communication of System:**  
Assistive listening systems or adaptive technologies required by Sentence 3.8.2.9.(2) shall provide for the clear communication required for the exchange of information, goods and services.

(See Note A-3.8.3.19.)

**Note A-3.8.3.19.**  
Assistive Listening Systems. Examples of assistive listening systems include FM, infrared and induction loop systems. However, the technology in this field is advancing rapidly; as such, other types of assistive listening systems could be considered in the design of a space. In choosing the most appropriate system, a number of factors must be taken into account including cost, installation and maintenance requirements, suitability for the intended user or audience, ease of operation, and the need for privacy. Information on designers and suppliers of such systems can be obtained from the Canadian Hearing Society. The intent of Article 3.8.3.19. is to provide clear communication where information, goods or services are provided to the public.

Wireless sound transmission systems, including FM, infrared and magnetic induction loop systems, improve sound reception for persons who are hard of hearing by providing amplification that can be adjusted by each user while blocking out unwanted background noise. Some of these systems transmit a signal that is picked up by a special receiver (FM, infrared) available for use by a person who is hard of hearing, whether or not a hearing aid is used. None of the systems interfere with the listening enjoyment of others.

The transmitter can be connected into an existing public address (P.A.) system amplifier or used independently with microphones. The induction loop system (see Figure A-3.8.3.19.-C) requires users with a hearing aid or cochlear implant to be in the area circumscribed by the loop; though installation of the loop is relatively simple, the installer should be knowledgeable about these systems if proper functioning is to be achieved. FM and infrared systems can be designed to broadcast signals that cover the entire room and thus do not restrict seating to any one area.

Figures A-3.8.3.19.-A and A-3.8.3.19.-B show the general configuration of FM and infrared systems. Although portable systems (FM systems, in particular) are available, these are best suited to small audiences. Generally, the systems installed in church halls, auditoria, theatres and similar places of assembly are not easily portable, as they are installed in a fixed location by a sound technician and form an integral part of the P.A. system of the room or building.

Hard-wired systems (where a connection is provided at a particular seat in an auditorium, for example) might meet this requirement when adequate provisions are made to accommodate persons with hearing aids.



### (3.2.7.1) Minimum Lighting Requirements

- 1) **Light Along Paths of Travel**  
An accessible path of travel required by Section 3.8., an exit, a public corridor, or a corridor providing access to exit for the public or serving patients' sleeping rooms or classrooms shall be equipped to provide illumination to an average level not less than 50 lx at floor or tread level and at angles and intersections at changes of level where there are stairs or ramps.
- 2) **Minimum Illumination Level**  
The minimum level of the illumination required by Sentence (1) shall be 10 lx.
- 3) **Illumination in Public Spaces**  
Rooms and spaces used by the public shall be equipped to provide illumination as described in Sentences (4) to (7) and Article 9.34.2.7.
- 4) **Illumination at Escalators and Moving Walks**  
The minimum level of illumination over the entire length of escalators and moving walks shall be not less than 100 lx at the level of the treads and walking surfaces.
- 5) **Illumination at Controls**  
Except as provided in Sentence (6) and except for light switches and internally illuminated controls, the minimum level of illumination at controls required by Article 3.8.2.6. shall be not less than 100 lx.
- 6) **Illumination at Controls with Visual Information**  
Where visual information is provided at controls referred to in Sentence (5), the minimum level of illumination at the controls shall be not less than 200 lx, except where the visual information is internally illuminated.
- 7) **Illumination at Signs**  
Except for internally illuminated signs, the minimum level of illumination at signs displaying visual information required by Clauses 3.4.6.10.(5)(b) and 3.4.6.16.(5)(g), Subclause 3.4.6.16.(5)(l)(ii), Clause 3.4.6.16.(6)(d), Sentence 3.4.6.18.(3), Clause 3.4.6.18.(4)(a) and Articles 3.4.6.19. and 3.8.2.10. shall be not less than 200 lx.
- 8) **Lighting Outlets**  
Lighting outlets in a building of residential occupancy shall be provided in conformance with Subsection 9.34.2.



# 5 ADAPTABLE DWELLING UNITS

Reserved for  
Adoption in 2025



### < Reserved for Adoption in 2025 >

< Adaptable unit requirements prescribed under 2018 of the BC Building Code will remain in effect prior to March 10, 2025 as outlined in the Order of the Minister of Housing No. BA 2023 10, unless there are other influences (e.g. CMHC funding) requiring new adaptable unit design requirements to be followed >

< See additional information and clarifications on adaptable dwelling units provided in BSSB Technical Bulletin B24-09 >

#### (3.8.5.1) Application

##### 1) Applicable Dwelling Unit Types

Except as provided in Sentence (2), this Subsection applies to

- one storey dwelling units served by an accessible interior public corridor and an accessible common building entrance, as required to be accessible by Articles 3.8.2.2. and 3.8.2.3., and
- common spaces and facilities intended for use by the residents of the dwelling units described in Clause (a) including common rooftop occupancies.

##### 2) Reinforcement for Grab Bars in Future

Buildings described in Clause 3.8.2.1.(1)(a) including secondary suites and all other dwelling units to which this Section applies shall, as required by Sections 3.7. and 9.31., provide at least one bathroom with walls reinforced in accordance with Clause 3.8.5.7.(1)(e).

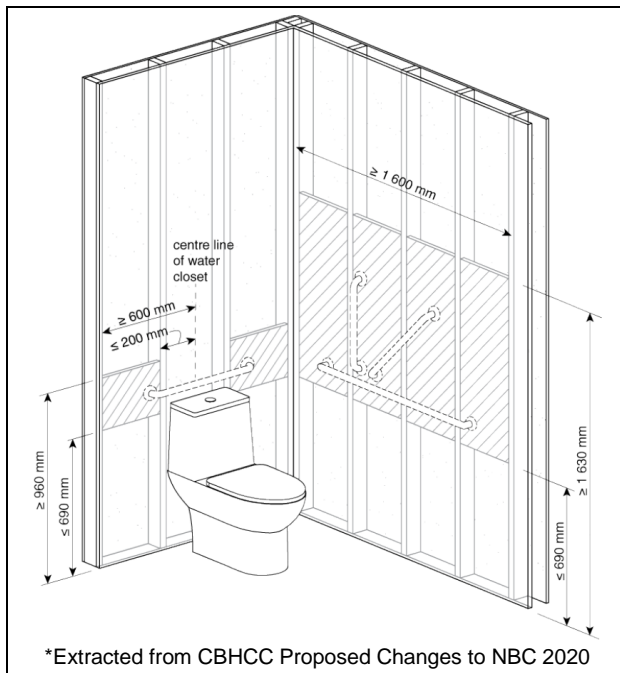

3.8.5.1.(2) Grab Bar Reinforcement Example

#### (3.8.5.2) Construction Requirements

##### 1) Required Adaptable Design

The construction of adaptable dwelling units and the building in which they are located shall conform to the requirements of this Subsection and, as required by this Subsection, to access requirements for buildings of residential occupancy elsewhere in this Code.

##### 2) Overlapping of Clear Floor Spaces

Unless otherwise required, clear areas and spaces required in this Subsection are permitted to overlap with other clear area and space requirements.

##### 3) Not Requiring Spaces but When They Are Provided

This Subsection does not require an adaptable dwelling unit be provided with a living space, a bedroom, a bathroom or a kitchen, but when provided, those spaces and the paths connecting them shall conform to the applicable requirements of this Subsection. < Note: Units like studio apartments are still permitted >

### (3.8.5.3) Building Access Requirements

- 1) **Accessible Access to Common Areas from Unit**  
Common areas, spaces and facilities and all common exterior and interior paths of travel serving adaptable dwelling units shall be accessible in accordance with Subsection 3.8.2. with floor areas protected in conformance with Article 3.3.1.7.
- 2) **Lighting Along Path to Unit**  
Common corridors and passageways serving adaptable dwelling units shall be equipped to provide illumination, measured at floor or tread level, of not less than 50 lx.
- 3) **Special Outlet for Future Strobe**  
Each adaptable dwelling unit shall be provided with special outlet boxes and cover plates as described in Sentences 3.2.4.19.(7).
- 4) **Accessible Access to Non-Common Areas**  
Unless otherwise required by this Section, common spaces and paths of travel that are not intended to serve the residents of adaptable dwelling units need not be accessible.

### (3.8.5.4) Doors

- 1) **Principal Entrance Clear Width**  
The principal entrance door to adaptable dwelling units shall have a clear width of not less than 850 mm when the door is in the open position.
- 2) **Clear Floor Space at Principal Entrance**  
Except as provided in Sentence (5), there shall be a clear floor space in accordance with Sentences 3.8.3.6.(14) and (15) adjacent to and on both sides of the adaptable dwelling unit entrance door described in Sentence (1).
- 3) **Clear Width of Doors Within Unit**  
Within an adaptable dwelling unit, every doorway along a path of travel connecting the entrance door described in Sentence (1) with a living space, adaptable bedroom, adaptable bathroom, and adaptable kitchen shall have a clear width of not less than 850 mm when the door is in the open position.
- 4) **Clear Floor Space at Doors Within Unit**  
Except as provided in Sentence (5), there shall be a clear floor space in accordance with Sentences 3.8.3.6.(14) and (15) adjacent to and on both sides of the doorways described in Sentence (3)
- 5) **Pre-Wired Power Door Operators**  
Doorways provided with power door operators, or provided with a special outlet box and cover plates that are designed, located and wired specifically to accommodate the future installation of a power door operator, may provide the clear floor space described in Sentence 3.8.3.6.(16).

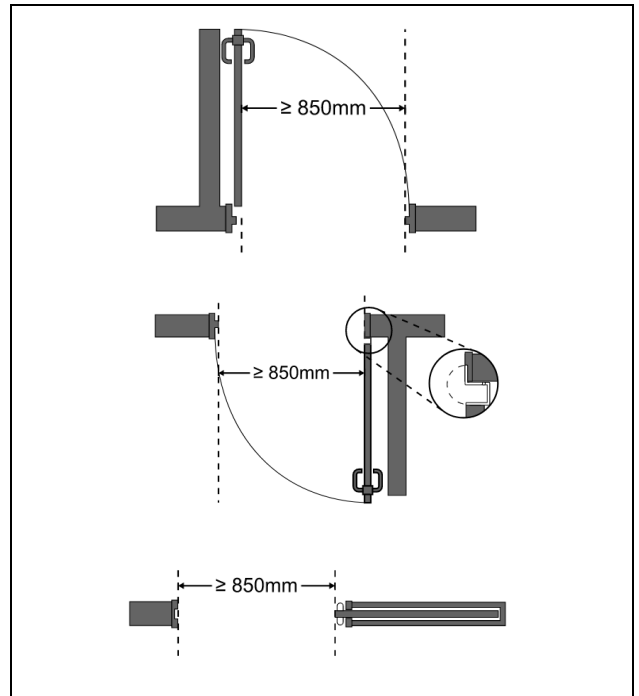

3.8.5.4. Clear Width

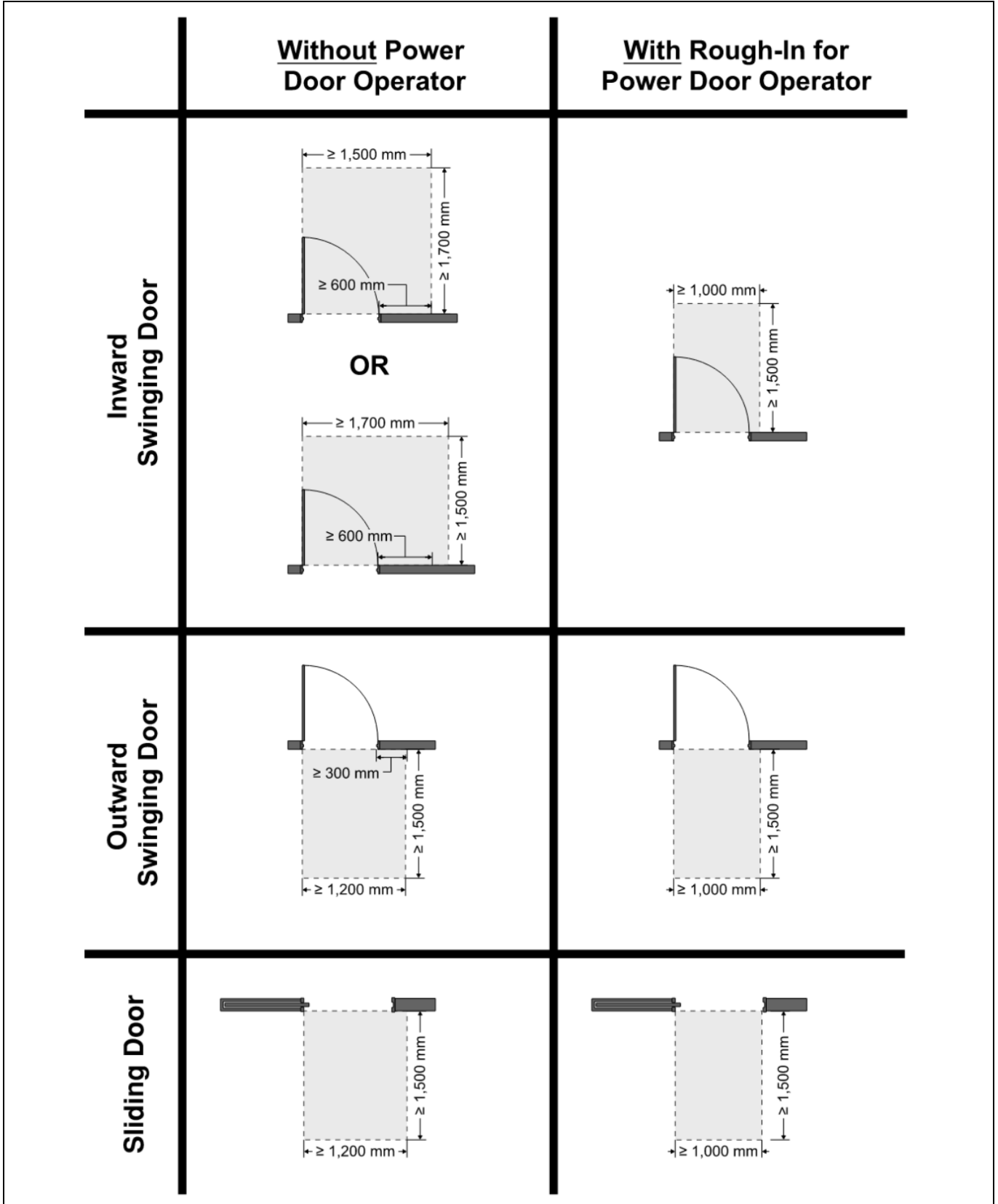

3.8.5.4. Adaptable Clear Floor Space at Doors

### (3.8.5.5) Hallways and Corridors

#### 1) Path of Travel Clear Width Within Unit

Hallways and corridors in adaptable dwelling units forming a path of travel connecting the entrance door described in Sentence 3.8.5.4.(1) with a living space, adaptable bedroom, adaptable bathroom and adaptable kitchen shall have a clear width conforming to Sentences 3.8.3.2.(1) and (2).

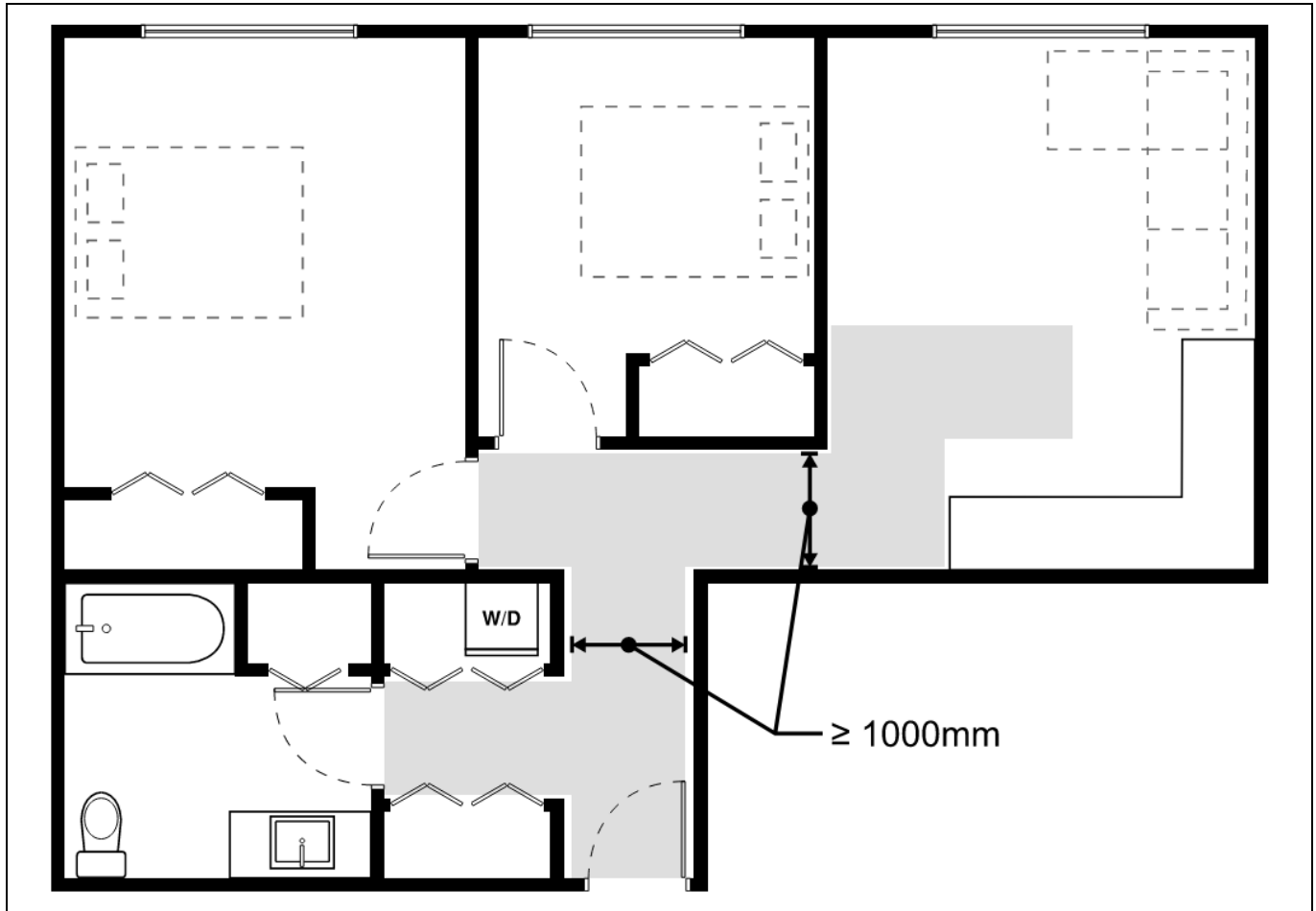

3.8.5.5. Clear Path of Travel within Dwelling Unit

### (3.8.5.6) Bedrooms

#### 1) Bedroom Design Requirements

At least one bedroom or sleeping space in an adaptable dwelling unit shall have

- a) a floor area that permits a turning area of not less than 1 700 mm in diameter, or not less than 1 700 mm by 1 500 mm, that could be adjacent a bed,
- b) a pathway clearance of not less than 850 mm wide, that could be unobstructed by a bed, to allow functional use of the bedroom, and
- c) at least one closet that provides
  - i) a clear opening width of not less than 900 mm, and
  - ii) a clear floor space, that need not be separate from the turning areas required in Clause (a), of not less than 1 700 mm in diameter or 1 700 mm by 1 500 mm on at least one side of the closet. (See Note A-3.8.5.6.(1).)

#### Note A-3.8.5.6.(1)

Adaptable Dwelling Unit Floor Area. An adaptable dwelling unit bedroom shall be designed so that furniture will not be a barrier to functional use of the space. Occupant load is regulated by this Code though beds and furniture are not. Subsection 3.1.17. establishes an occupant load of two people per sleeping room. As such, it is reasonable to account for a bed that can sleep two people and functional maneuvering space adjacent the bed and throughout the room or space. Designs should allow for the bed to be located to accommodate transfer from the turning area to either side of the bed.

#### BCBC Interpretation 24-0021

1. Bedroom does not need to accommodate 2 people (i.e. double bed not necessary for adaptability).
2. 850mm clearance is not prescribed on both sides of the bed but is prescribed from the entry door to the bed transfer space along with to any controls intended to be frequently operated, such as operable windows and light switches.
3. The size of the adaptable bedroom can be based on a single bed tight to the wall on one side, provided clearances like noted in #2 are still achieved.

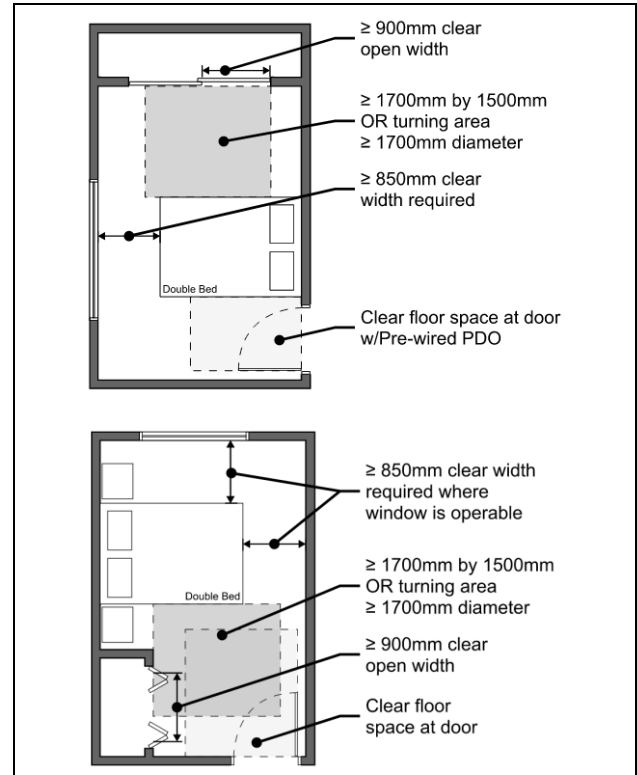

3.8.5.6. Bedroom Clear Floor Space

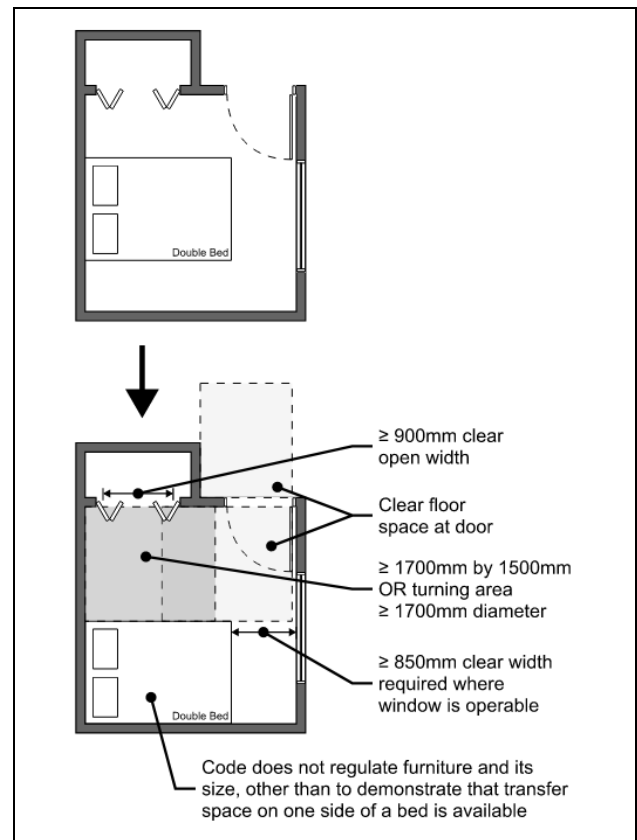

3.8.5.6. Demonstrating Adaptable Clear Floor Space can be Provided

### (3.8.5.7) Bathrooms

#### 1) Bathroom Design Requirements

At least one bathroom in an adaptable dwelling unit shall be designed to be adaptable for use by persons with disabilities by providing

- a clear lateral transfer space adjacent a water closet conforming to Clause 3.8.3.12.(1)(b),
- a distance between the centre line of the water closet and the wall on one side of 460 mm to 480 mm,
- a plumbing system that accommodates the future installation of a lavatory with a clear space in accordance with Clauses 3.8.3.16.(1)(a) to (f) that does not impede the space for or use of other fixtures described in this Article (see Note A-3.8.5.7.(1)(c) and (d)),
- a plumbing system that accommodates the future installation of a
  - shower described in Sentence 3.8.3.17.(1) that does not impede the space for or use of other fixtures described in this Article, or
  - bathtub described in Sentence 3.8.3.18.(1) that does not impede the space for or use of other fixtures described in this Article (see Note A-3.8.5.7.(1)(c) and (d)), and

#### Note A-3.8.5.7.(1)(c) and (d)

Plumbing Systems. Plumbing systems that accommodate the future installation of fixtures means that the water supply as well as drainage and venting systems are located so that the future installation of an accessible fixture does not require redesign of the system. An example is a sink that can be installed at multiple different heights without requiring a change to where the DWV pipe penetrates the wall.

#### BCBC Interpretation 24-0022

- The water closet in the adaptable bathroom must be adjacent to a wall.
- The water closet in the adaptable bathroom must be able to provide a 900mm side clearance.
- The bathtub in an adaptable bathroom is to be provided with a 1700mm diameter clear floor area unless the plumbing system is designed that it can accommodate a shower in future.

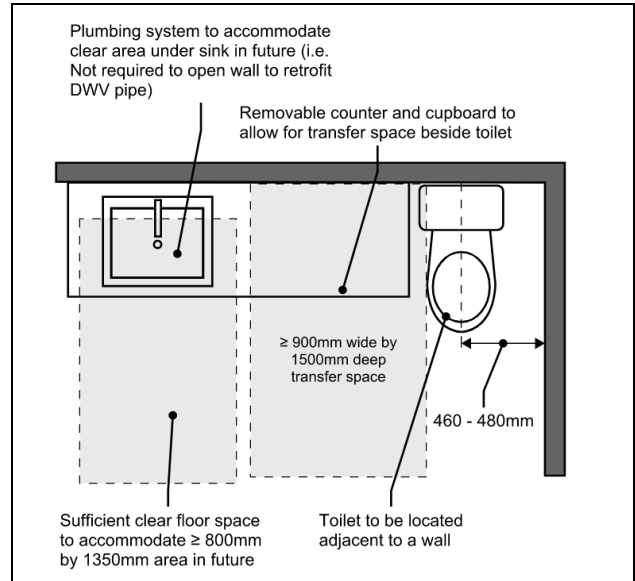

3.8.5.7. Water Closet & Lavatory

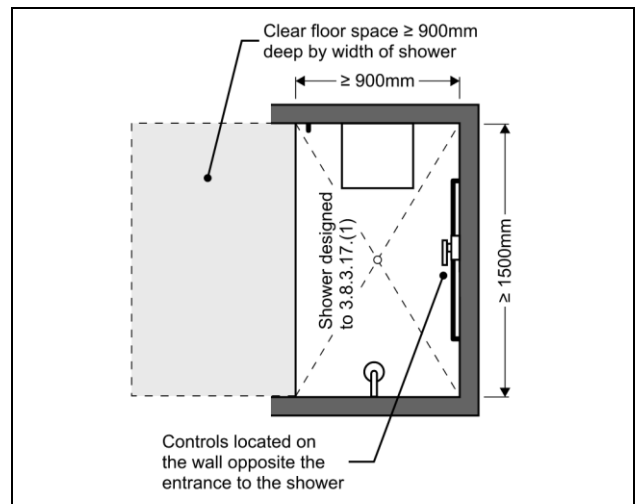

3.8.5.7. Shower Design

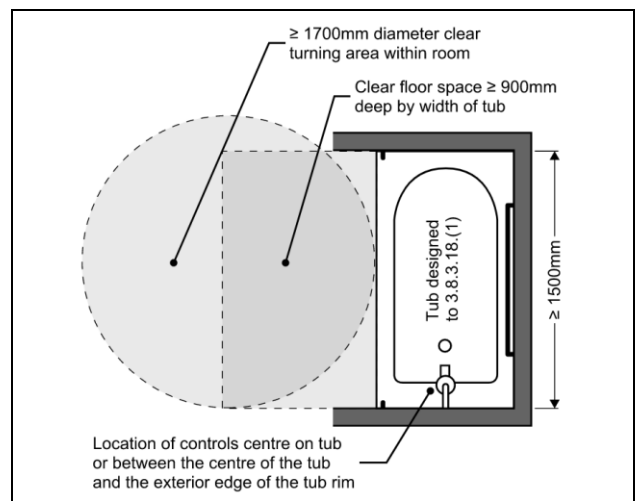

3.8.5.7. Bathtub Design

- e) walls adjacent the water closet and shower or bathtub location reinforced to accommodate the future installation of grab bars conforming to
- Clauses 3.8.3.12.(1)(f) and (g) for water closets, and
  - Clause 3.8.3.17.(1)(f) for showers or Clauses 3.8.3.18.(1)(f) for bathtubs (see Note A-3.8.5.7.(1)(e)).

**Note A-3.8.5.7.(1)(e)**

Reinforced Grab Bar Location. This provision is intended to ensure there is adequate backing for the installation of grab bars by the occupant in the future. For example, plywood or solid lumber behind the wall finish and encompassing the location of future grab bars located as described in Clauses 3.8.3.12.(1)(f) and (g) and Clause 3.8.3.17.(1)(f) or 3.8.3.18.(1)(f) would provide suitable backing for grab bar fasteners.

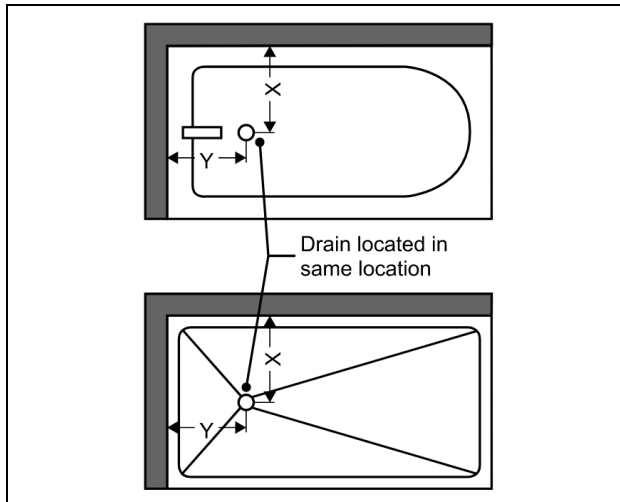

3.8.5.7.(1)(d) Accommodating Retrofitting of Plumbing

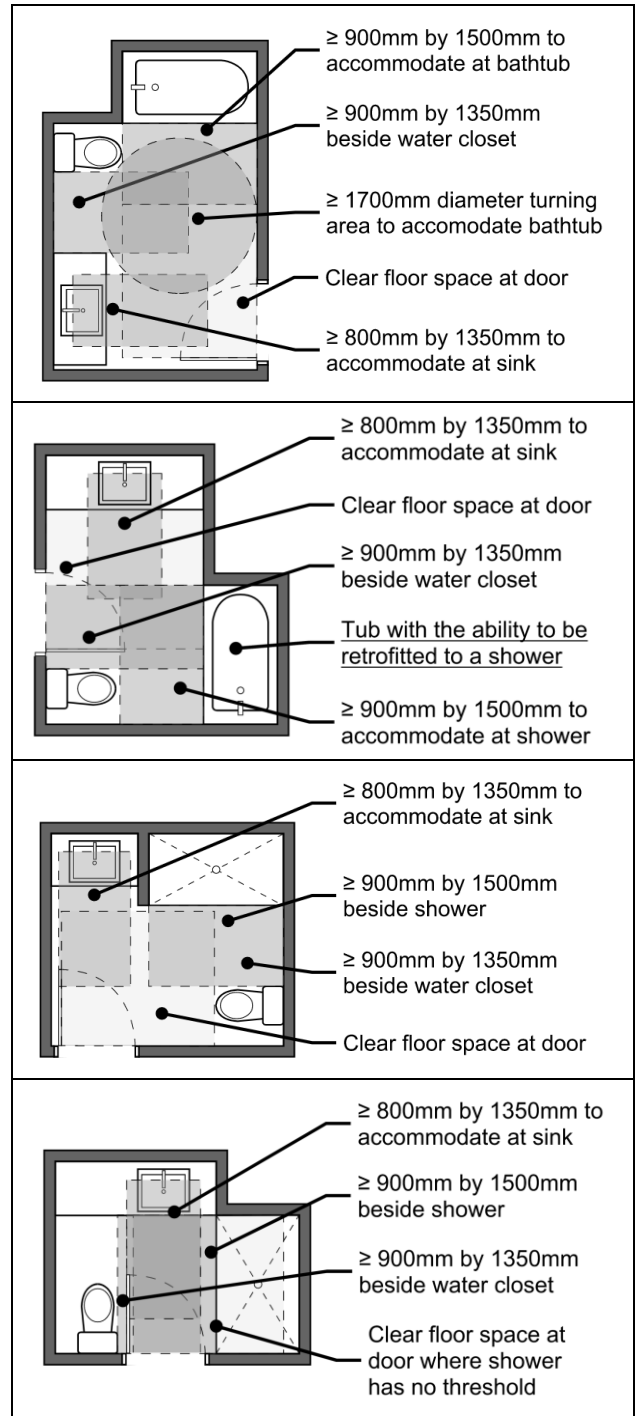

3.8.5.7. Examples of Washroom Layouts and Clear Floor Spaces



**(3.8.5.8) Kitchens**

- 1) **Countinous Counter Between Sink and Cooktop**  
The kitchen in an adaptable dwelling unit shall be designed so that the cooktop and sink are adjacent or can have a continuous counter between them.
- 2) **Clear Floor Space Within Kitchen**  
A clear floor space shall be provided in the kitchen area that is not less than 1 700 mm in diameter or 1 700 mm by 1 500 mm.
- 3) **Plumbing for Kitchen Sink**  
The plumbing system serving the kitchen shall accommodate the future installation of a kitchen sink that could be installed in accordance with the requirements for the installation of a lavatory as described in Clauses 3.8.3.16.(1)(b) to (f). (See Note A-3.8.5.7.(1)(c) and (d).)

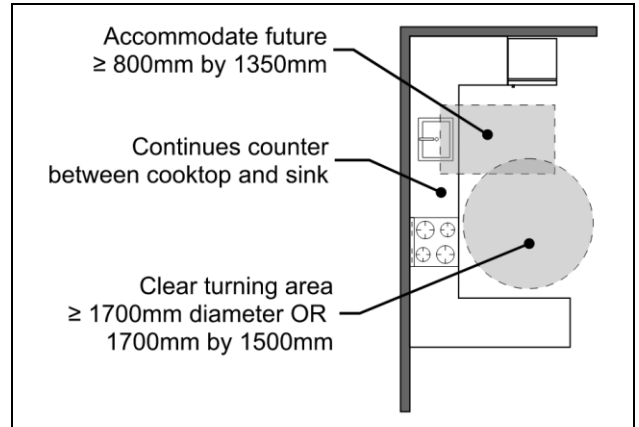
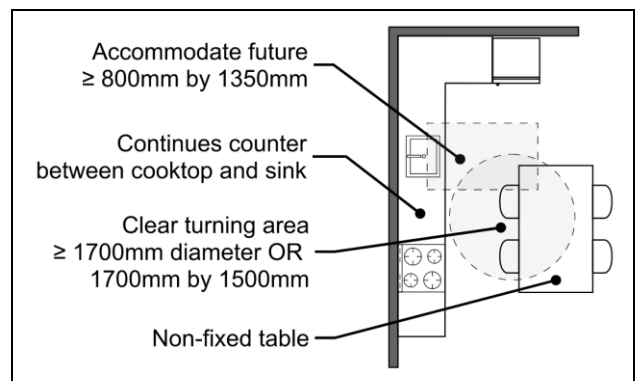
**3.8.5.8. Kitchen Clear Floor Space****3.8.5.8. Kitchen Clear Floor Space with Furniture**

### (3.8.5.9) Controls, Switches and Outlets

#### 1) Installation Requirements

Except as provided in Sentence (2), controls and switches for building systems and outlets in adaptable dwelling units, that are intended for frequent operation by occupants, shall not require activities for operation below 400 mm from the floor or above 1 200 mm from the floor.

#### 2) Exemptions

Sentence (1) does not apply to controls, switches and dedicated outlets for equipment or appliances.

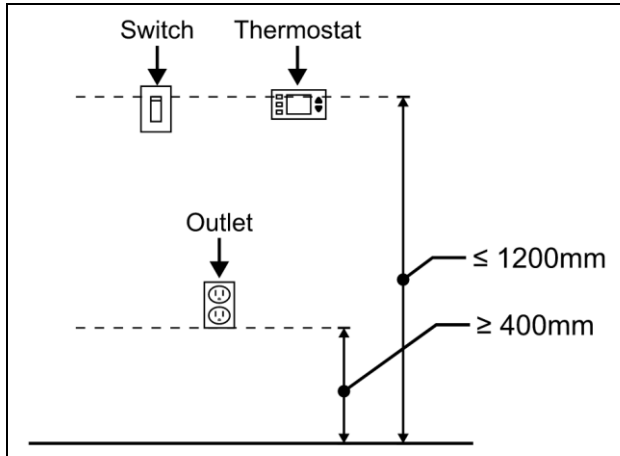

3.8.5.9. Control Heights

### (3.2.4.19) Special Outlet for Future Strobe

#### 7) Special Outlet for Strobe Design Requirements

Each adaptable dwelling unit shall be provided with special outlet boxes and cover plates that

- a) are designed, located and wired specifically to allow strobe lights to operate in conformance with
  - i) Sentence (5) where a fire alarm system is provided, or
  - ii) Sentence (6) where a fire alarm system is not provided,
- b) are permanently identified as "FIRE – Strobe Light Connection Only,"
- c) are installed in the locations described in Clause (4)(e), and
- d) for the purposes of providing power to the strobe lights that may be connected to the outlet boxes, are assumed that the total special outlets for at least 20 percent of the adaptable dwelling units in the building are in use.

#### 3.2.4.19.(4)(e), (5), & (6) Visible Signals

- 4) Visible signal devices shall be installed in the rooms and spaces required by Article 3.2.4.20. and Section 3.8. and shall
  - e) be installed in each
    - i) sleeping room or bed space
    - ii) room closed off from the living area by a door, including bathrooms, and
    - iii) living area and any hallway serving the living area
- 5) The visible signal devices required by Sentence (4) shall
  - a) consist of strobe lights conforming to CAN/ULC-S526, "Visible Signaling Devices for Fire Alarm and Signaling Systems, Including Accessories," that are designed to operate as part of the fire alarm system, and
  - b) be located in conformance with the installation requirements for visible signal devices in CAN/ULC-S524, "Standard for Installation of Fire Alarm Systems."
- 6) Where a fire alarm system is not provided, the visible signal devices required by Sentence (4) shall
  - a) consist of strobe lights conforming to CAN/ULC-S526, "Visible Signaling Devices for Fire Alarm and Signaling Systems, Including Accessories,"
  - b) be connected to, and activated by,
    - i) the smoke alarms required by Article 3.2.4.20. and 9.10.19.1., or
    - ii) the smoke detectors permitted by Articles 3.2.4.20., 3.2.4.21. or 9.10.19.8., and
  - c) be located not less than 2 100 mm above the floor on a wall or ceiling in a location that will maximize effectiveness.

#### BCBC Interpretation 24-0012

1. A special outlet box is prescribed to be roughed in an ensuite bathrooms.
2. A special outlet box is not prescribed to be roughed in a small storage rooms / closets.

6.0 ADAPTABLE UNIT EXAMPLE PLANS

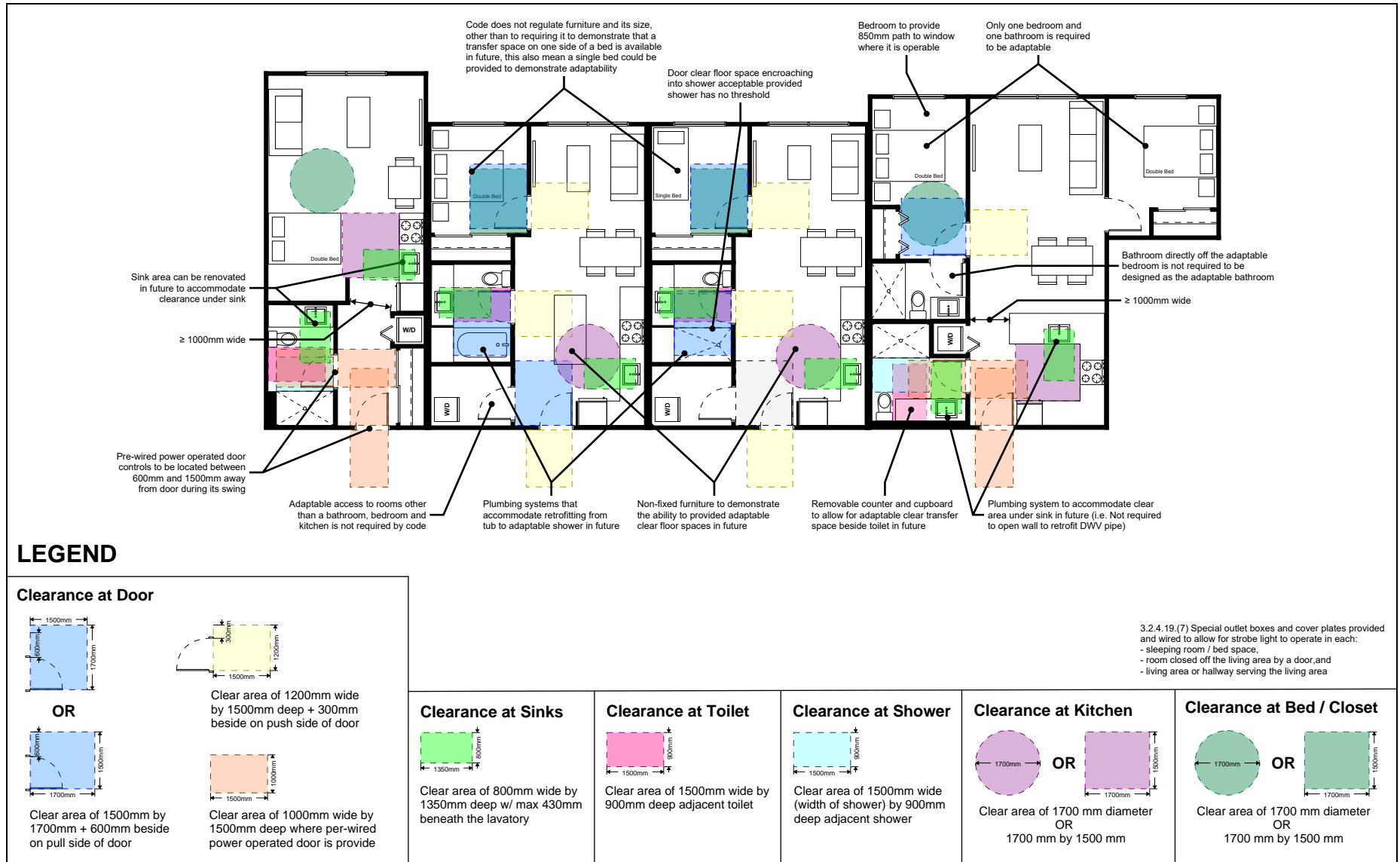

3.8.5. Adaptable Unit Design Examples (General)



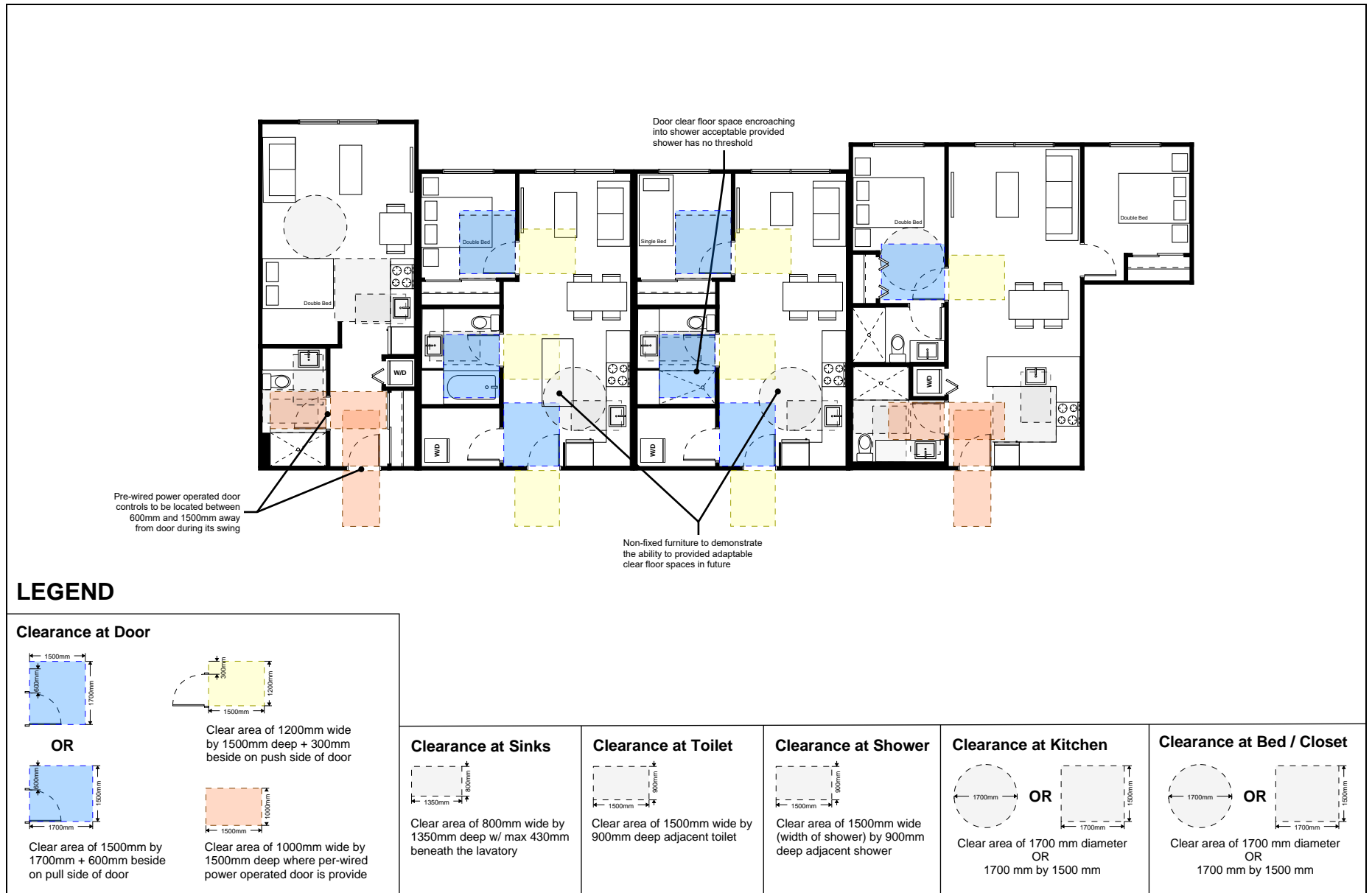

3.8.5. Adaptable Unit Design Examples (Clearance at Doors)



**LEGEND**

**Clearance at Door**

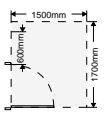

OR

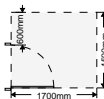

Clear area of 1500mm by 1700mm + 600mm beside on pull side of door

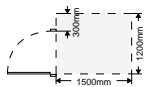

Clear area of 1200mm wide by 1500mm deep + 300mm beside on push side of door



Clear area of 1000mm wide by 1500mm deep where per-wired power operated door is provide

**Clearance at Sinks**

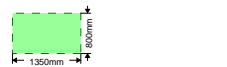

Clear area of 800mm wide by 1350mm deep w/ max 430mm beneath the lavatory

**Clearance at Toilet**



Clear area of 1500mm wide by 900mm deep adjacent toilet

**Clearance at Shower**

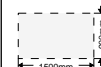

Clear area of 1500mm wide (width of shower) by 900mm deep adjacent shower

**Clearance at Kitchen**

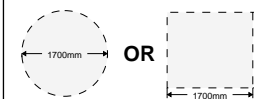

Clear area of 1700 mm diameter OR 1700 mm by 1500 mm

**Clearance at Bed / Closet**

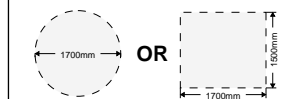

Clear area of 1700 mm diameter OR 1700 mm by 1500 mm

**3.8.5. Adaptable Unit Design Examples (Clearance at Sink)**



**LEGEND**

**Clearance at Door**

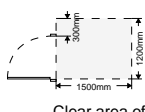
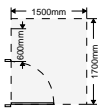

OR

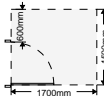

Clear area of 1200mm wide by 1500mm deep + 300mm beside on push side of door



Clear area of 1000mm wide by 1500mm deep where per-wired power operated door is provide

Clear area of 1500mm by 1700mm + 600mm beside on pull side of door

**Clearance at Sinks**

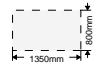

Clear area of 800mm wide by 1350mm deep w/ max 430mm beneath the lavatory

**Clearance at Toilet**

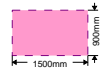

Clear area of 1500mm wide by 900mm deep adjacent toilet

**Clearance at Shower**

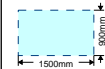

Clear area of 1500mm wide (width of shower) by 900mm deep adjacent shower

**Clearance at Kitchen**

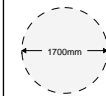

OR

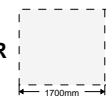

Clear area of 1700 mm diameter OR 1700 mm by 1500 mm

**Clearance at Bed / Closet**

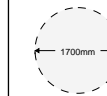

OR



Clear area of 1700 mm diameter OR 1700 mm by 1500 mm

**3.8.5. Adaptable Unit Design Examples (Clearance at Toilet & Shower)**





**LEGEND**

**Clearance at Door**

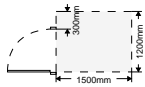
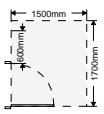

OR

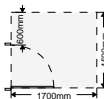

Clear area of 1200mm wide by 1500mm deep + 300mm beside on push side of door



Clear area of 1000mm wide by 1500mm deep where per-wired power operated door is provide

Clear area of 1500mm by 1700mm + 600mm beside on pull side of door

**Clearance at Sinks**

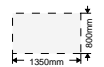

Clear area of 800mm wide by 1350mm deep w/ max 430mm beneath the lavatory

**Clearance at Toilet**

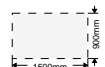

Clear area of 1500mm wide by 900mm deep adjacent toilet

**Clearance at Shower**

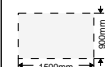

Clear area of 1500mm wide (width of shower) by 900mm deep adjacent shower

**Clearance at Kitchen**

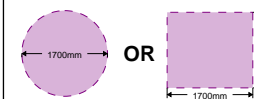

Clear area of 1700 mm diameter OR 1700 mm by 1500 mm

**Clearance at Bed / Closet**

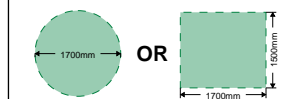

Clear area of 1700 mm diameter OR 1700 mm by 1500 mm

**3.8.5. Adaptable Unit Design Examples (Clearance at Kitchen & Bedroom)**





**GHL**  
**CONSULTANTS LTD**

**Suite 800 – 700 West Pender Street  
Vancouver BC V6C 1G8**

**Phone: (604) 689-4449**

**Email: [tech@ghl.ca](mailto:tech@ghl.ca)**

**Web: [www.ghl.ca](http://www.ghl.ca)**